



Floorcare & Specialty Motors

Model: 122177-00

SPECIAL FEATURES

- 1500+ hours life (Infinity Brush)
- 670 Peak Air Watts
- Up to 45% Overall Efficiency
- High efficient cooling system
- Lamb "Green Power Label"
- UL recognized, category PRGY2 (E47185)
- CSA certification pending
- Same mounting patern as Lamb's 7.2 tangential-bypass
- Optional filtered cooling air and locked-rotor, blocked cooling air and running overload protection
- Optional new patent-pending bearing protection for wet applications. (122178-18)

DESCRIPTION

- Double-stage tapered fan system
- 8.4" / 213 mm diameter
- Improved sound quality
- "True" tangential discharge bracket
- 240 volts AC
- 3.5" High-Efficiency lamination
- Double ball bearings; 10mm output

DESIGN APPLICATION

- Commercial and Residential Central Cleaning Systems
- Car wash vac and blower systems
- Equipment operating in environments requiring separation of working air from motor ventilating air
- Designed to handle clean, dry, filtered air only

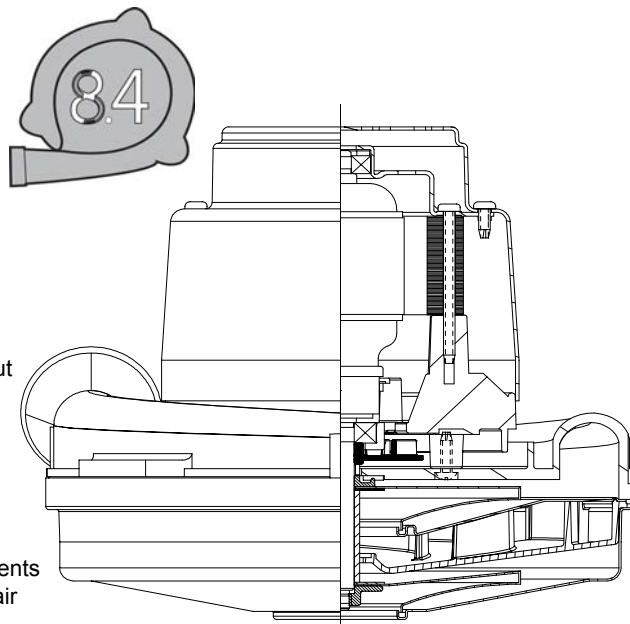

**PRELIMINARY BULLETIN
(SUBJECT TO CHANGE)**

PEAK AIRWATTS

685

Calculated in accordance with ASTM F2105

TYPICAL MOTOR PERFORMANCE.*

(At 240 volts, 60Hz, test data is corrected to standard conditions of 29.92 Hg, 68° F.)

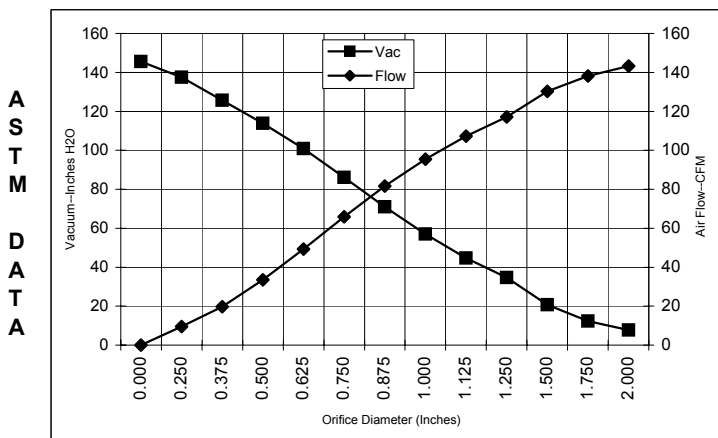

Orifice (Inches)	Amps	Watts (In)	RPM	Vac (In.H2O)	Flow (CFM)	Air Watts
2.000	7.1	1598	22590	7.7	143.2	129
1.750	7.1	1605	22587	12.3	138.1	200
1.500	7.2	1614	22453	20.8	130.3	318
1.250	7.2	1610	22587	34.7	117.1	478
1.125	7.1	1598	22587	44.7	107.2	563
1.000	7.1	1592	22587	57.0	95.5	640
0.875	7.0	1576	22587	71.0	81.7	682
0.750	6.7	1513	22983	86.1	65.9	667
0.625	6.2	1412	23777	100.9	49.4	586
0.500	5.6	1272	24963	113.9	33.5	449
0.375	4.9	1118	26410	125.6	19.7	292
0.250	4.3	997	27730	137.5	9.5	153
0.000	3.8	884	29577	145.5	0.0	0

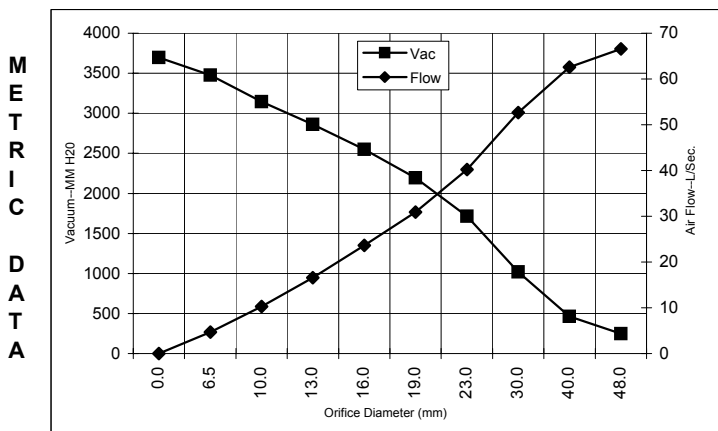

Orifice (mm)	Amps	Watts (In)	RPM	Vac (mm H2O)	Flow (L/Sec)	Air Watts
48.0	7.1	1601	22589	246	66.5	160
40.0	7.2	1611	22493	463	62.6	283
30.0	7.1	1603	22587	1021	52.7	525
23.0	7.0	1580	22587	1714	40.2	672
19.0	6.7	1511	22999	2193	30.9	665
16.0	6.2	1416	23745	2548	23.6	589
13.0	5.7	1286	24845	2860	16.6	463
10.0	5.0	1141	26193	3146	10.3	315
6.5	4.3	1003	27664	3478	4.7	160
0.0	3.8	884	29577	3696	0.0	0

Note: Metric Performance data is calculated from the ASTM data above.

* Data represents performance of a typical motor sampled from a large production quantity. Individual motor data may vary due to normal manufacturing variations.

Test Specs:	240	Minimum Sealed Vacuum:	140.0	ORIFICE:	7/8"	Minimum Vacuum:	65"	Maximum Watts:	1750
--------------------	-----	-------------------------------	-------	-----------------	------	------------------------	-----	-----------------------	------

DIMENSIONS



NOTES:

1. LEADS: 16GA. STRANDED, BLACK.
2. MOTOR IDENTIFICATION: MANUFACTURER'S NAME, MODEL NUMBER, VOLTAGE, FREQUENCY, INSPECTORS CODE WITH "FF" SUFFIX, DATE OF MANUFACTURE, AGENCY RECOGNITION CODE, PLANT LOCATION CODE, PATENT PENDING" AND COUNTRY OF ORIGIN.
3. MOUNTING MUST NOT RESTRICT THIS DIAMETER.
4. ALLOW [0.0026 SQ. IN.] / 4.0 SQ. IN. (MIN.) FOR COOLING AIR INTAKE.
5. COOLING AIR INTAKE MUST BE SEPARATED FROM COOLING AIR EXHAUST.
6. COOLING AIR EXHAUST MUST BE SEPARATED FROM VACUUM EXHAUST.

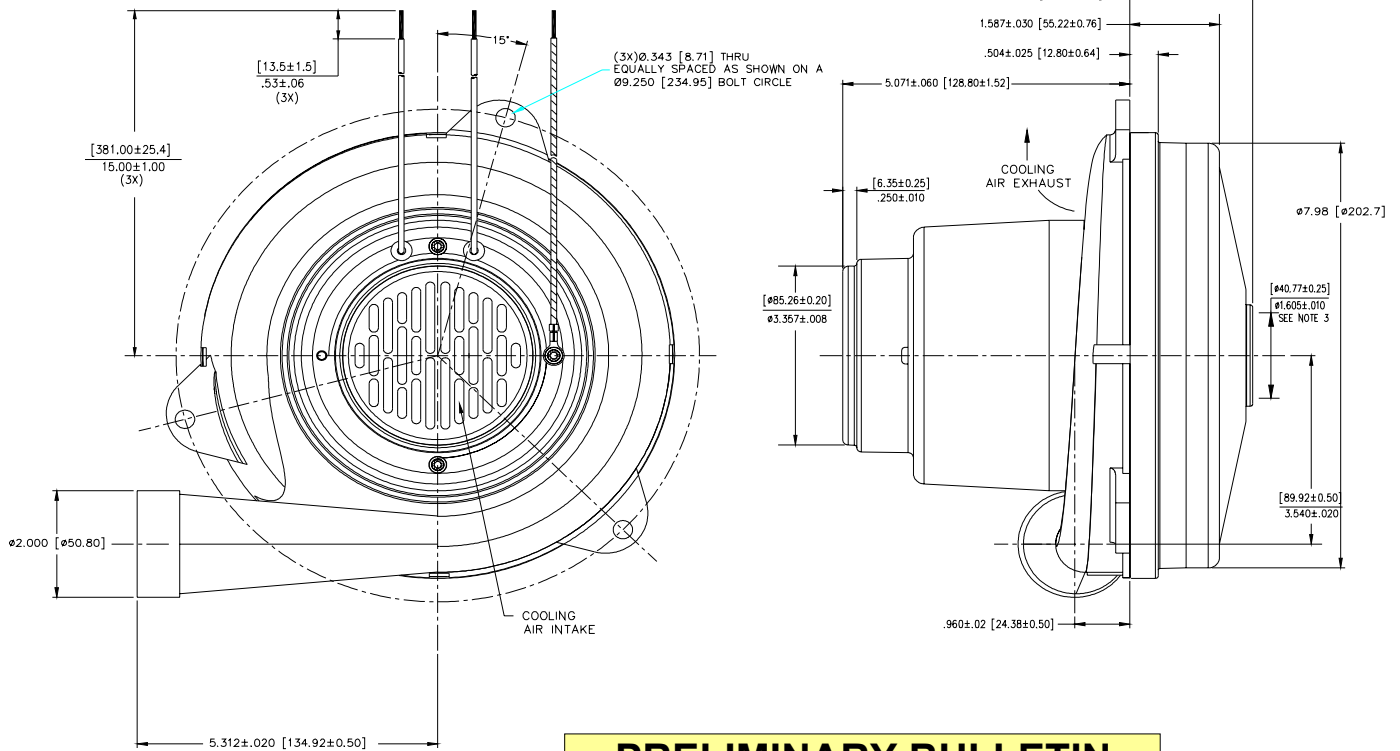

PRELIMINARY BULLETIN
(SUBJECT TO CHANGE)

IMPORTANT NOTE: Pictorial and dimensional data are subject to change without notice. Contact factory for current revision levels.

WARNING - When using AMETEK Floorcare & Specialty Motors (F&SM) bypass motors in machines that come in contact with foam, liquid (including water), or other foreign substances, the machine must be designed and constructed to prevent those substances from reaching the fan system, motor housing, and electrical components. F&SM vacuum motors other than hazardous duty models should not be applied in machines that come in contact with dry chemicals or other volatile materials. Failure to observe these precautions could cause flashing (depending on volatility) or electrical shock which could result in property damage and severe bodily injury, including death in extreme cases. All applications incorporating F&SM motors should be submitted to appropriate organizations or agencies for testing specifically related to the safety of your equipment.

AMETEK/Floorcare & Specialty Motors
www.ametekfsm.com

Issued: March, 2009