

LAMB ELECTRIC

Model: 116406-13

DESCRIPTION

- Two stage
- 36 volts
- 5.7"/145 mm diameter
- Double ball bearings
- Single speed
- Peripheral bypass discharge
- Thermoset fan end bracket
- Aluminum commutator bracket

DESIGN APPLICATION

- Equipment operating in environments requiring separation of working air from motor ventilating air
- Designed to handle clean, dry, filtered air only

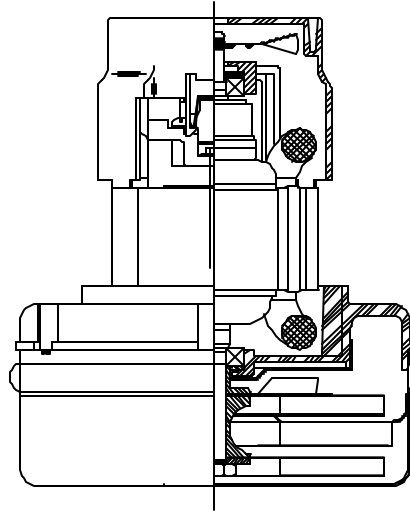

SPECIAL FEATURES

- Suitable for 36 volt DC operation
- UL recognized, category PRGY2 (E47185)
- Provision for grounding
- Skeleton-frame design
- Epoxy painted fan case
- Patented air seal bearing construction. U.S. Patent #4,088,424
- The Lamb Electric vacuum motor line offers a wide range of performance levels to meet design needs.

TYPICAL MOTOR PERFORMANCE.*

(At 36 volts DC, test data is corrected to standard conditions of 29.92 Hg, 68° F.)

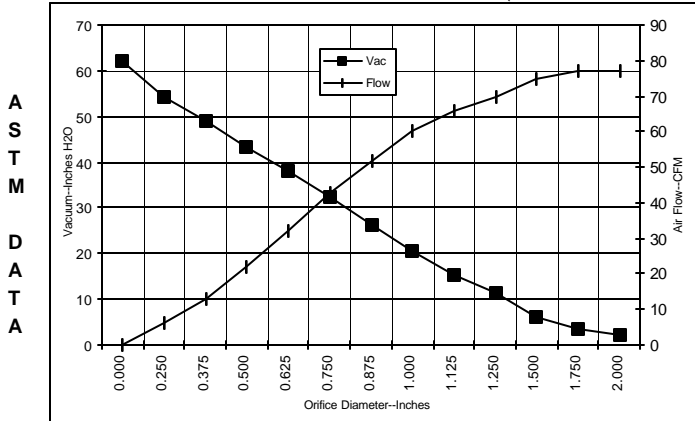

Orifice (Inches)	Amps	Watts (In)	RPM	Vac (In.H ₂ O)	Flow (CFM)	Air Watts
2.000	14.9	548	14663	2.1	77.0	19
1.750	14.9	550	14638	3.6	77.0	32
1.500	15.0	553	14613	6.2	75.0	55
1.250	15.1	557	14550	11.4	70.0	94
1.125	15.1	557	14550	15.3	66.0	119
1.000	15.1	555	14588	20.4	60.0	144
0.875	14.9	549	14713	26.2	52.0	161
0.750	14.6	536	14988	32.5	43.0	163
0.625	14.0	514	15450	38.1	32.0	144
0.500	13.3	489	16088	43.5	22.0	112
0.375	12.5	461	16875	48.9	13.0	75
0.250	11.8	436	17713	54.2	6.0	39
0.000	11.3	414	18563	62.0	0.0	0

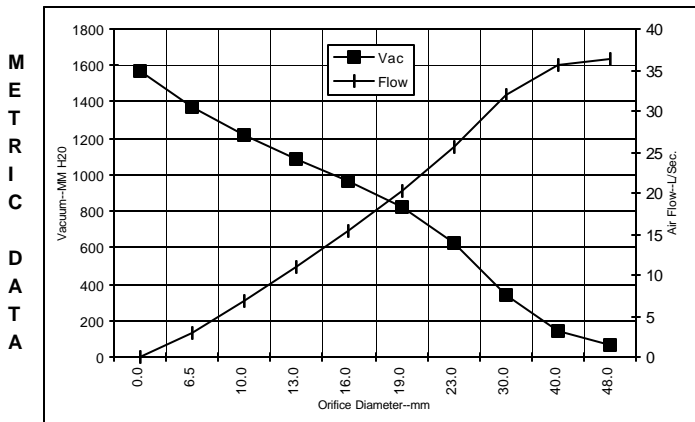

Orifice (mm)	Amps	Watts (In)	RPM	Vac (mm H ₂ O)	Flow (L/Sec)	Air Watts
48.0	14.9	549	14652	70	36.3	25
40.0	15.0	552	14621	138	35.7	48
30.0	15.1	557	14550	344	32.0	108
23.0	15.0	551	14682	629	25.5	157
19.0	14.6	536	14997	828	20.2	163
16.0	14.0	515	15432	962	15.3	145
13.0	13.4	492	16024	1091	10.9	115
10.0	12.6	465	16757	1221	6.8	81
6.5	11.8	437	17671	1370	3.0	41
0.0	11.3	414	18563	1575	0.0	0

Note: Metric performance data is calculated from the ASTM data above.

* Data represents performance of a typical motor sampled from a large production quantity. Individual motor data may vary due to normal manufacturing variability.

Test Specs:	36 volts	Minimum Sealed Vacuum:	58.7"	ORIFICE:	7/8 "	Minimum Vacuum:	24.0"	Maximum Watts:	646
-------------	----------	------------------------	-------	----------	-------	-----------------	-------	----------------	-----

DIMENSIONS

NOTES:

1. LEADS: 14 GA STRANDED. LEADS CAN BE ANY COLOR EXCEPT GREEN OR GREEN WITH YELLOW STRIPE.
2. GROUNDING OR EARTHING PROVISIONS. USE HOLES AS INDICATED FOR GROUNDING OR EARTHING. REFER TO APPROPRIATE LISTING OR REGULATORY AGENCY FOR PROPER METHOD OF GROUNDING OR EARTHING.
3. RECOMMENDED SCREW SIZE 10-18 TYPE BT OR TYPE 25 THREAD CUTTING SCREW. MAXIMUM PENETRATION 17.40/.685.

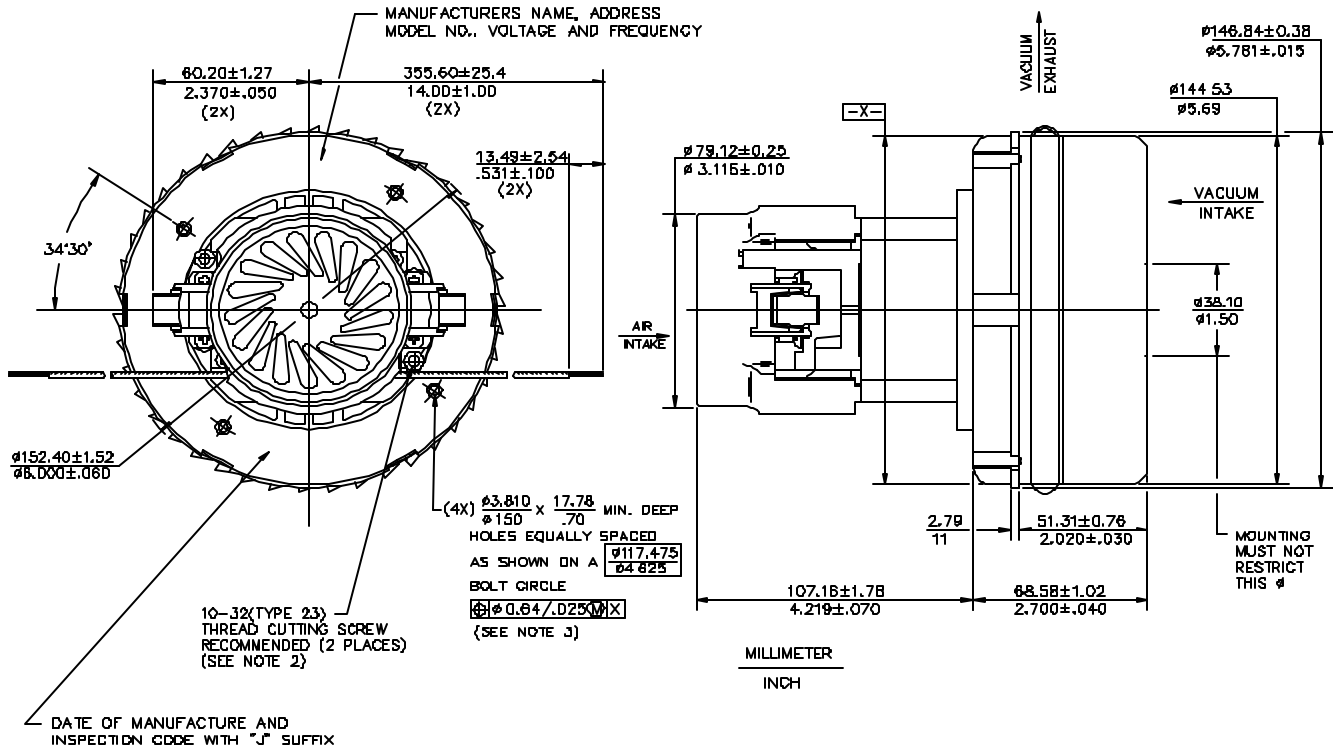

IMPORTANT NOTE: Pictorial and dimensional data are subject to change without notice. Contact factory for current revision levels.

WARNING - When using AMETEK Lamb Electric bypass motors in machines that come in contact with foam, liquid (including water), or other foreign substances, the machine must be designed and constructed to prevent those substances from reaching the fan system, motor housing, and electrical components. Lamb Electric vacuum motors other than hazardous duty models should not be applied in machines that come in contact with dry chemicals or other volatile materials. Failure to observe these precautions could cause flashing (depending on volatility) or electrical shock which could result in property damage and severe bodily injury, including death in extreme cases. All applications incorporating Lamb Electric motors should be submitted to appropriate organizations or agencies for testing specifically related to the safety of your equipment.

AMETEK/Lamb Electric Division
627 Lake Street
Kent, Ohio 44240
U.S.A.
Tel: (330) 673-3451
Fax: (330) 673-8994

Ametek GmbH
Weilimdorfer Str. 47
D-70825 Korntal-Munchingen
Germany
Phone: + 49-711-838-7876
Fax: + 49-711-838-7862

AMETEK/Singapore Private Limited
10 Ang Mo Kio Street 65
05-12 Techpoint
Singapore 2056
Tel: + 65-484-2388
Fax: + 65-481-6588