

5.7" (145mm) BLDC Bypass Blower

24 VDC Input, High Flow System

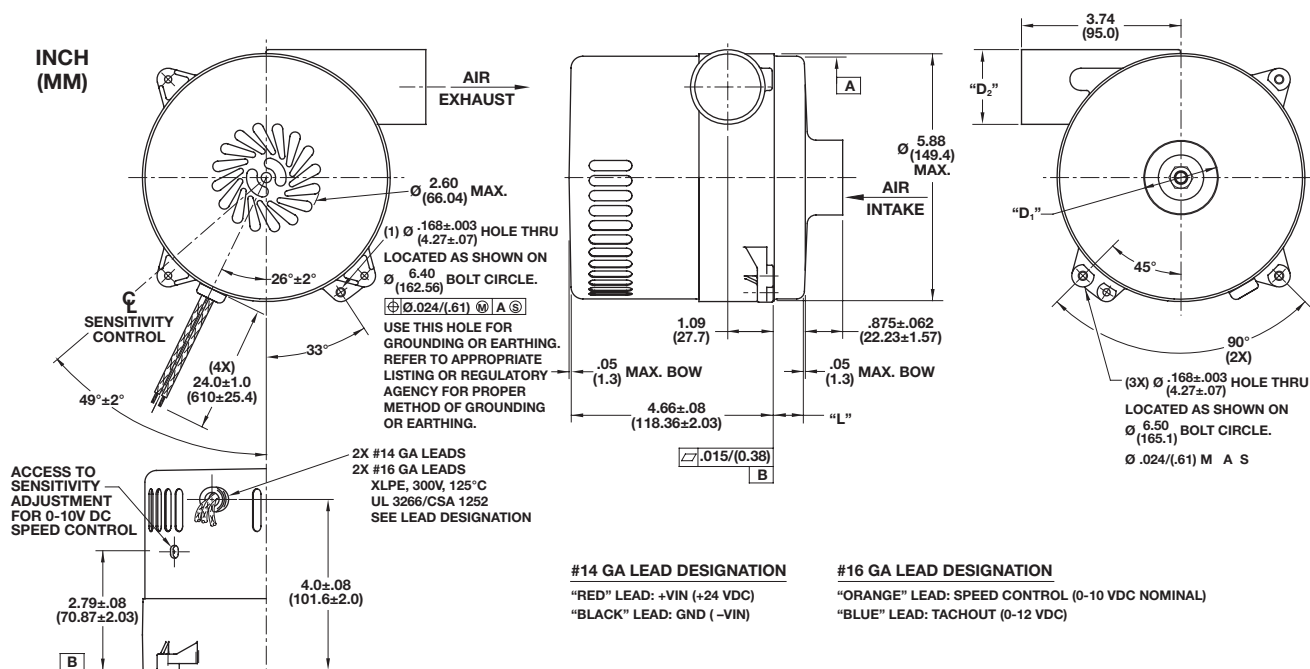

Blower Data	Unit of Measure	Part Number		
Electrical Speed Control		150403 E	150404 E	150405 E
Mechanical Speed Control		150434 M	150435 M	150436 M
Flow	—	High Flow	High Flow	Ultra High Flow
Stages	—	1	2	1
Input Voltage Range	Volts DC	18 - 30	18 30	18 - 30
Pressure, Maximum (Sealed Pressure)	In. H ₂ O, sealed	31	54	22
	mbar	77	134	54
Airflow, Maximum (CFM)	CFM	125	110	190
	m ³ /hr	212.4	186.9	322.8
Air Intake Diameter (Dimension "D1" above)	Inches	1.75	1.75	2.75
	mm	44.45	44.45	69.85
Air Exhaust Diameter (Dimension "D2" above)	Inches	1.75	1.75	2.5
	mm	44.45	44.45	63.5
Length (Dimension "L" above)	Inches	0.33	1.25	0.7
	mm	8.38	31.75	17.78

NOTES:

- **Temperature:** Working Air: 0°C to 50°C.
- **Dielectric Testing:** 500 VDC applied for one second between input leads/wires and grounds, 3 mA leakage max.
- **Speed Control Input Current:** Less than 1mA at 10 volts DC.
- **Air performance data at 24 volts DC input.** Contact AMETEK for information concerning air performance at other than 24 volts DC.
- **Approximate Weight:** 6 lbs.

5.7" (145mm) BLDC Bypass Blower

24 VDC Input, High Flow System

TYPICAL PERFORMANCE

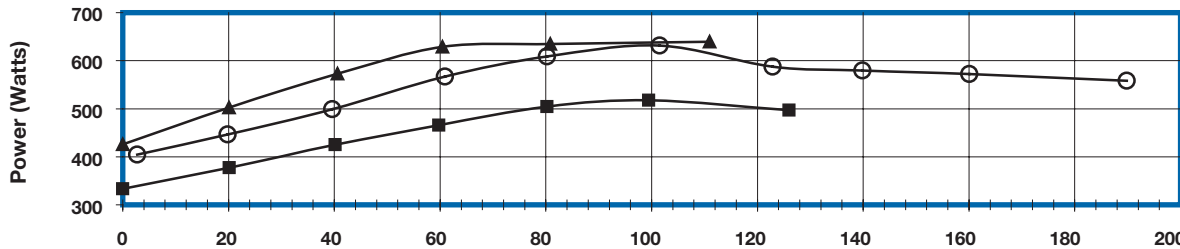
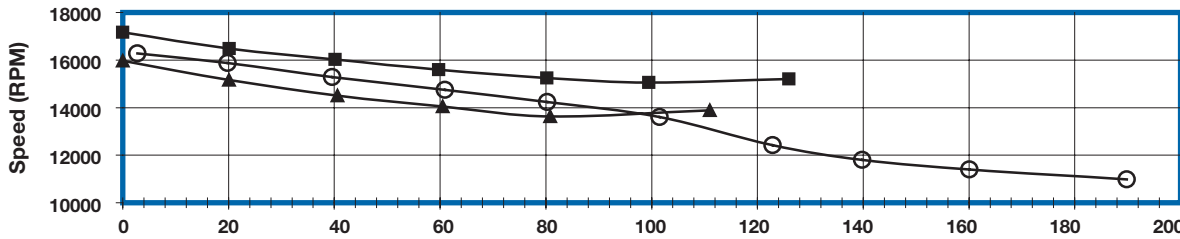
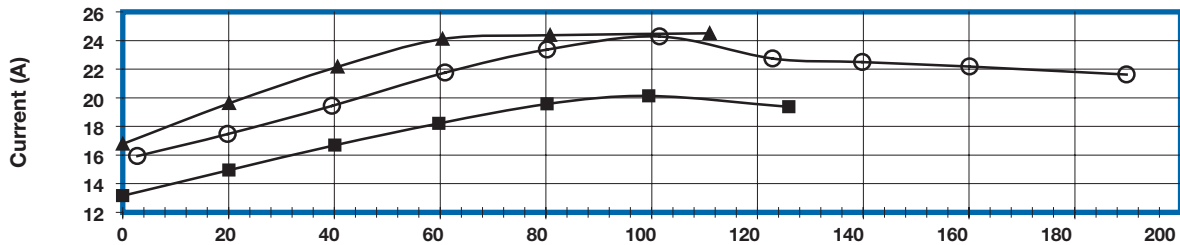
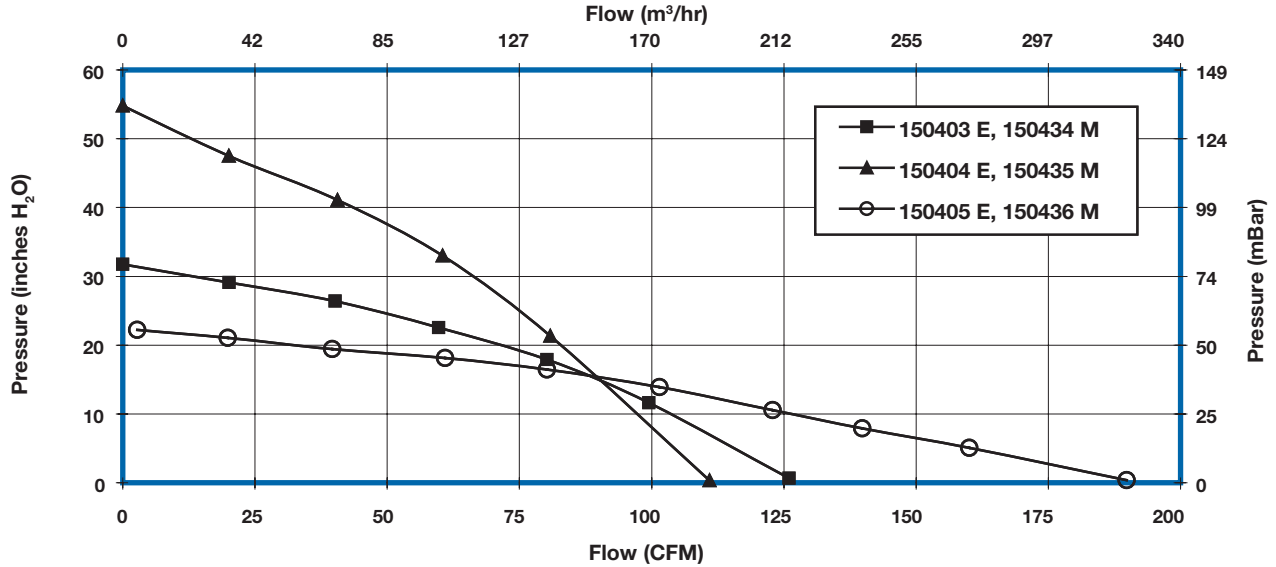

**LOW-VOLTAGE
BLDC BLOWERS**

This document is for informational purposes only and should not be considered as a binding description of the products or their performance in all applications. The performance data on this page depicts typical performance under controlled laboratory conditions using AMETEK BLDC motor controllers. Actual performance will vary depending on the operating environment and application. AMETEK products are not designed for and should not be used in medical life support applications. AMETEK reserves the right to revise its products without notification. The above characteristics represent standard products. For product designed to meet specific applications, contact AMETEK Technical & Industrial Products Marketing and Sales.

AMETEK TECHNICAL & INDUSTRIAL PRODUCTS

627 Lake Street, Kent OH 44240

Tel: +1 330-673-3452 • Fax: +1 330-677-3306 • www.ametektip.com