

NAPETOST	240V
VOLTAGE	
FREKVENCA	50/60Hz
FREQUENCY	
NAZIVNA MOČ	1000W
NOMINAL POWER	

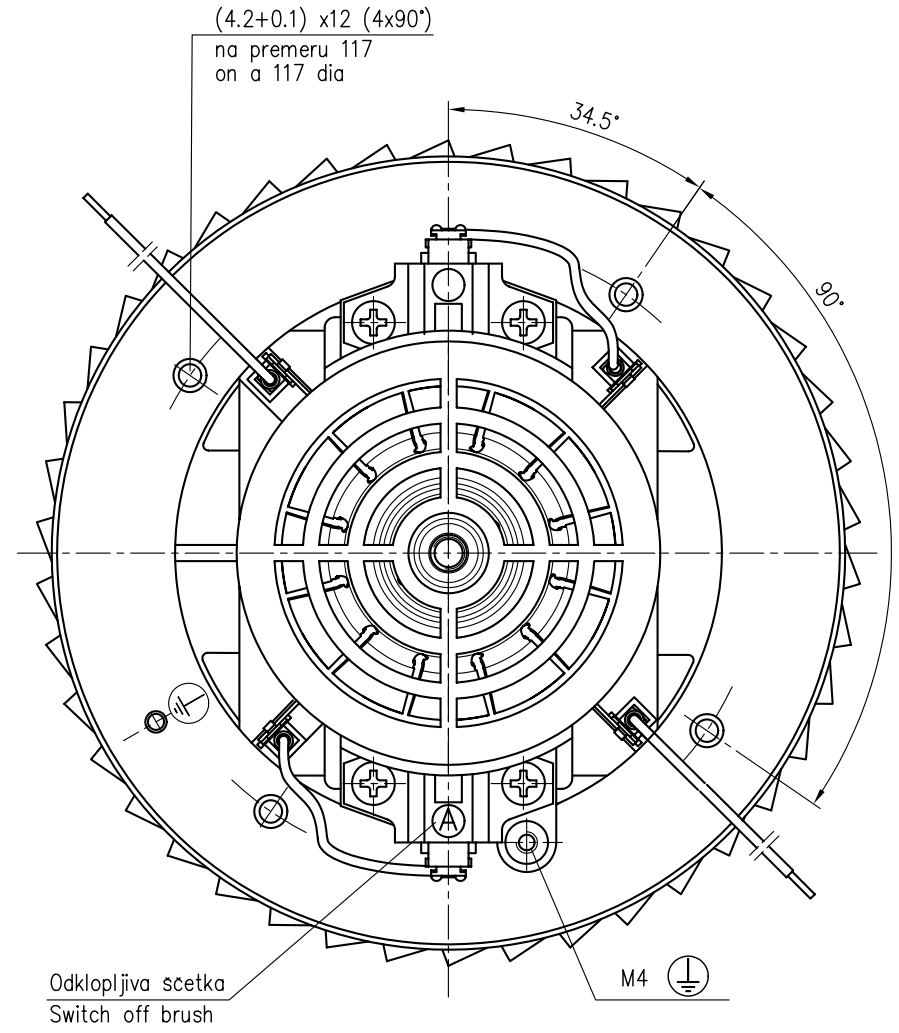
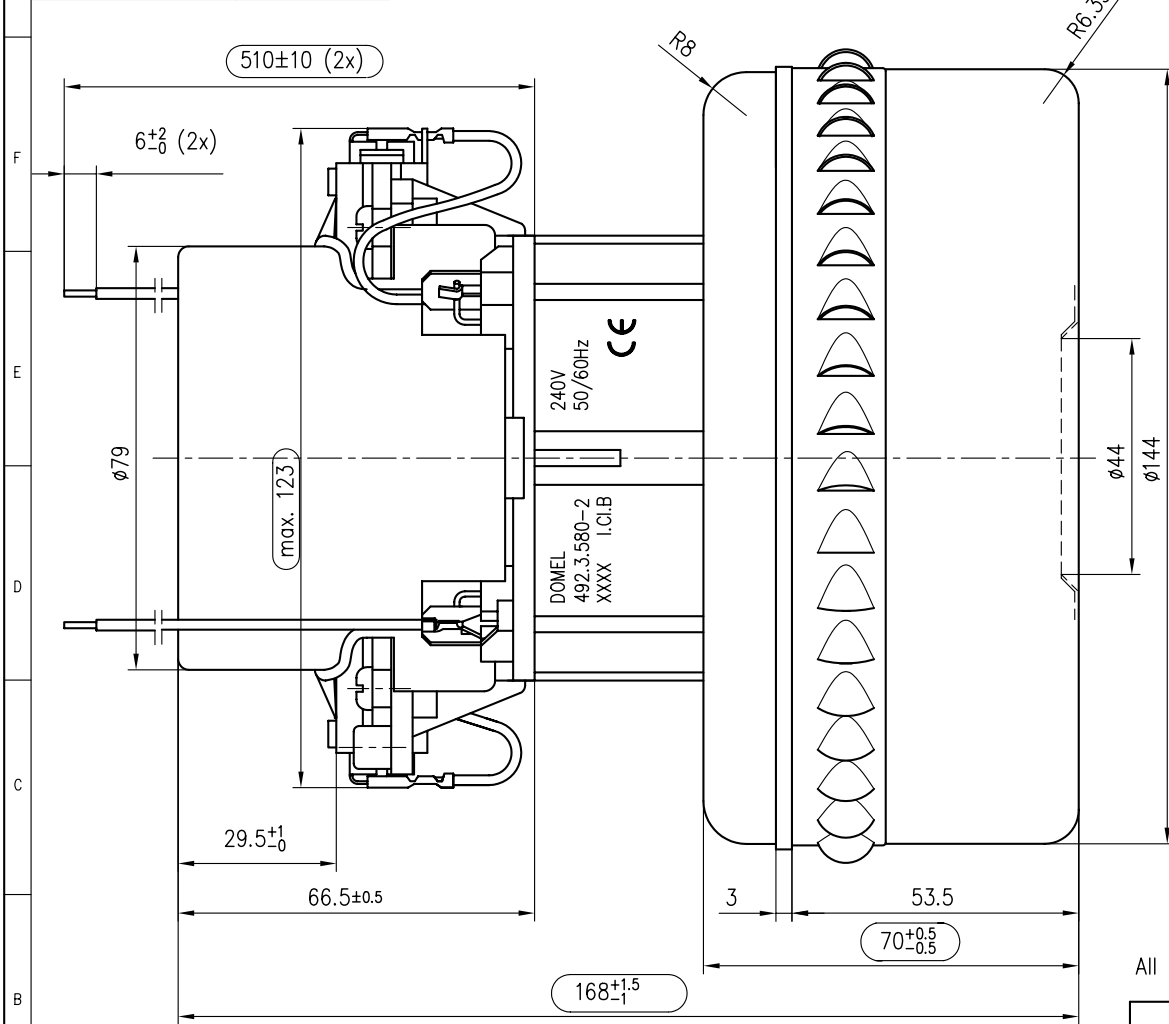

All dimensions in mm.

				Tolerance odprtih mer ISO 2768 - m	Površinska hrapavost	Merilo 1:1	Original format ISO 5457 - A3
				Datum 06.06.05	Ime J. Luznar	Naziv SESALNA ENOTA VACUUM CLEANER MOTOR	
				Koda 492.3.580-2		List 3+	Stran 1
Ozn.	St. obvestila	Datum	Ime	Otoki 21, 422B Zelezniki, Slovenija		Pripadnost	Namesto

OSNOVNE ZNAČILNOSTI		TYPICAL CHARACTERISTICS	
IZVEDBA	DVOSTOPENJSKA	FAN SYSTEM	TWO STAGE
VLEZAJENJE	DVA KROGLIČNA LEZAJA	BEARINGS	DUAL BALL
VRSTA PRETOKA	MIMO MOTORJA	DISCHARGE	BY PASS
SMER VRTENJA	LEVA	DIRECTION OF ROTATION	CCW

Obr.: 02-01/3  
Izdelano s CAD - ročno spreminjanje ni dovoljeno!  
Vsak prenos tretjim osebam ali uporaba v nedogovorjene namene ni dovoljena po zakonu o avtorskih pravicah