



Model: 122585-00

DESCRIPTION

- Two stage
- 120 volts
- 5.7"/145 mm diameter
- Double ball bearings
- Single speed
- Peripheral bypass discharge
- Aluminum fan end bracket
- Thermoset commutator bracket

DESIGN APPLICATION

- Equipment operating in environments requiring separation of working air from motor ventilating air
- Designed to handle clean, dry, filtered air only

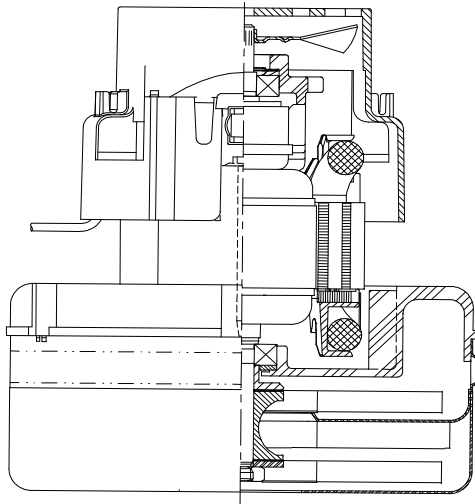

SPECIAL FEATURES

- Suitable for 120 volt AC operation, 50/60 Hz
- UL recognized, category PRGY2 (E47185)
- Provision for grounding
- Skeleton-frame design
- The Lamb Electric vacuum motor line offers a wide range of performance levels to meet design needs

TYPICAL MOTOR PERFORMANCE.*

(At 120 volts, 60Hz, test data is corrected to standard conditions of 29.92 Hg, 68° F.)

ASTM DATA

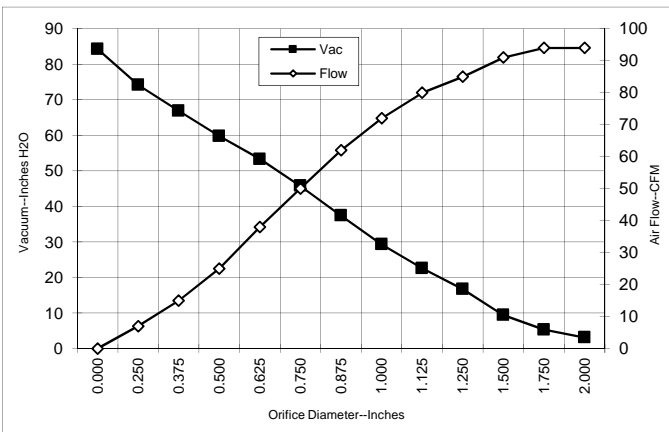

Orifice (Inches)	Amps	Watts (In)	RPM	Vac (In.H ₂ O)	Flow (CFM)	Air Watts
2.000	7.9	899	17800	3.1	94.0	34
1.750	7.9	903	17815	5.3	94.0	59
1.500	7.9	905	17750	9.4	91.0	100
1.250	8.0	916	17675	16.7	85.0	167
1.125	8.0	916	17650	22.6	80.0	212
1.000	8.0	913	17650	29.3	72.0	248
0.875	7.9	899	17850	37.4	62.0	274
0.750	7.6	869	18225	45.8	50.0	273
0.625	7.2	827	18800	53.3	38.0	238
0.500	6.8	780	19575	59.8	25.0	181
0.375	6.2	721	20450	66.9	15.0	120
0.250	5.7	667	21550	74.2	7.0	62
0.000	5.4	620	22450	84.3	0.0	0

METRIC DATA

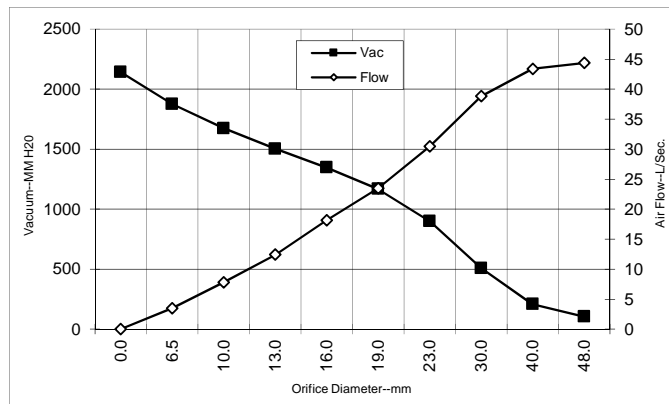

Orifice (mm)	Amps	Watts (In)	RPM	Vac (mm H ₂ O)	Flow (L/Sec)	Air Watts
48.0	7.9	901	17807	103	44.4	45
40.0	7.9	904	17770	208	43.4	88
30.0	8.0	916	17661	507	38.8	192
23.0	7.9	903	17800	899	30.4	268
19.0	7.6	868	18237	1167	23.5	272
16.0	7.2	829	18777	1346	18.2	239
13.0	6.8	785	19498	1502	12.4	187
10.0	6.3	730	20319	1672	7.8	129
6.5	5.7	670	21495	1875	3.5	65
0.0	5.4	620	22450	2141	0.0	0

Note: Metric performance data is calculated from the ASTM data above.

* Data represents performance of a typical motor sampled from a large production quantity. Individual motor data may vary due to normal manufacturing variations.

Test Specs:	120 volts	Minimum Sealed Vacuum:	80.0"	ORIFICE:	7/8 "	Minimum Vacuum:	33.0"	Maximum Watts:	1050
--------------------	-----------	-------------------------------	-------	-----------------	-------	------------------------	-------	-----------------------	------

DIMENSIONS

NOTES:

1. RECOMMENDED SCREW SIZE 10-16 TYPE BT OR TYPE 25 THREAD CUTTING SCREW. MAXIMUM PENETRATION [17.40]/.685.
2. MOTOR IDENTIFICATION: MANUFACTURER'S NAME, MODEL NUMBER, VOLTAGE, FREQUENCY, INSPECTORS CODE, DATE OF MANUFACTURE, AGENCY RECOGNITION CODE, PLANT LOCATION CODE, AND MADE IN THE USA.
3. ALLOW [0.0016 SQ M]/2.5 SQ IN. FOR COOLING AIR INTAKE.
4. COOLING AIR INTAKE MUST BE SEPERATED FROM COOLING AIR EXHAUST.
5. COOLING AIR EXHAUST MUST BE SEPERATED FROM VACUUM EXHAUST.
6. GROUND LEAD: 18 GAUGE STRANDED; COLOR: GREEN WITH YELLOW STRIPE.

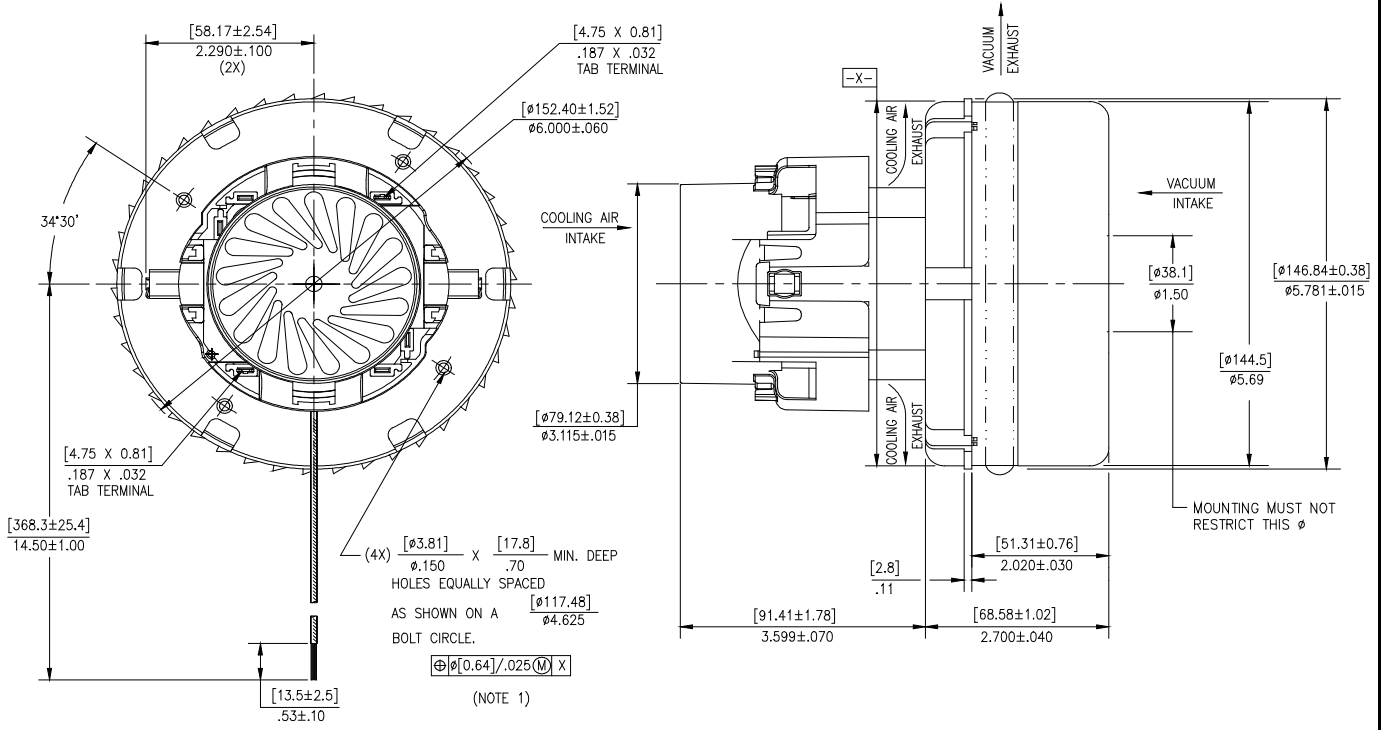

IMPORTANT NOTE: Pictorial and dimensional data are subject to change without notice. Contact factory for current revision levels.

WARNING - When using AMETEK Lamb Electric bypass motors in machines that come in contact with foam, liquid (including water), or other foreign substances, the machine must be designed and constructed to prevent those substances from reaching the fan system, motor housing, and electrical components. Lamb Electric vacuum motors other than hazardous duty models should not be applied in machines that come in contact with dry chemicals or other volatile materials. Failure to observe these precautions could cause flashing (depending on volatility) or electrical shock which could result in property damage and severe bodily injury, including death in extreme cases. All applications incorporating Lamb Electric motors should be submitted to appropriate organizations or agencies for testing specifically related to the safety of your equipment.

AMETEK/Floorcare & Specialty Motors
www.ametekfsm.com