

# AMETEK

## Floorcare & Specialty Motors

## Product Bulletin

Model: 122264-00/99

### Advantek III - Ultra II

### AIR WATT™ SERIES

#### DESCRIPTION

- Two stage
- 120 volts
- 5.7"/145 mm diameter
- Double ball bearings
- Single speed
- Thru-flow discharge
- Thermoset fan end bracket
- Stamped steel end bracket

#### DESIGN APPLICATION

- Equipment operating in environments not requiring separation of working air from motor ventilating air
- Designed to handle clean, dry, filtered air only

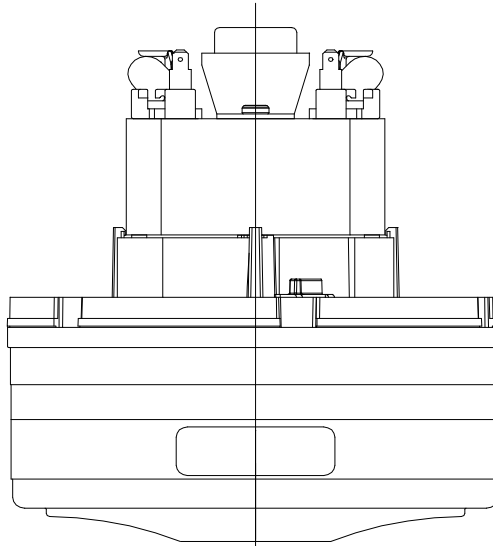

#### SPECIAL FEATURES

- **698 Peak Air Watts**
- Patented Advantek II diffusion
- 3" Commercial Lamination
- Dual Tapered fan system
- Provision for grounding
- Top end mounting boss
- Thermal Device
- UL recognized, category PRGY2 (E47185)
- Suitable for 120 volt AC operation, 50 or 60 Hz
- The Lamb vacuum motor line offers a wide range of performance levels to meet design needs

**PEAK AIRWATTS**  
**698**

Calculated in accordance with ASTM F2105

#### TYPICAL MOTOR PERFORMANCE.\*

(At 120 volts, 60Hz, test data is corrected to standard conditions of 29.92 Hg, 68°F.)

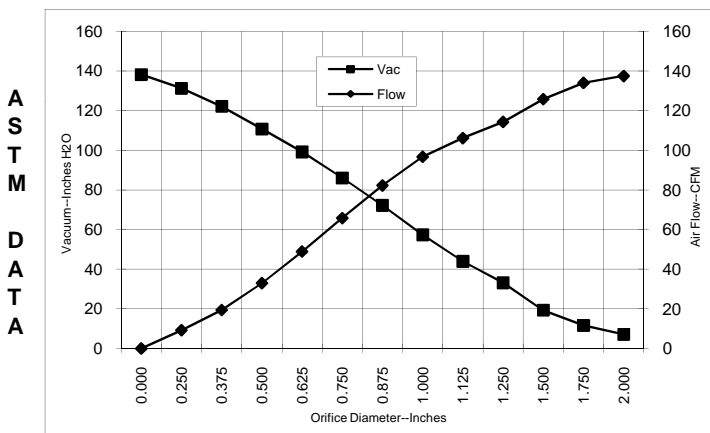

Orifice (Inches)	Amps	Watts (In)	RPM	Vac (In.H <sub>2</sub> O)	Flow (CFM)	Air Watts
2.000	14.5	1674	24582	7.1	137.5	113
1.750	14.5	1673	24534	11.6	134.0	182
1.500	14.4	1658	24583	19.3	125.8	285
1.250	14.4	1656	24674	33.1	114.3	443
1.125	14.3	1649	24862	43.9	106.2	547
1.000	14.1	1627	25010	57.3	96.7	643
0.875	13.8	1590	25301	72.2	82.3	698
0.750	13.0	1504	25970	86.0	65.8	664
0.625	12.1	1405	26878	99.1	48.9	568
0.500	19.9	1277	28179	110.7	33.0	429
0.375	9.7	1135	29712	122.1	19.4	278
0.250	8.8	1033	31059	131.2	9.2	142
0.000	8.0	952	32499	138.1	0.0	0

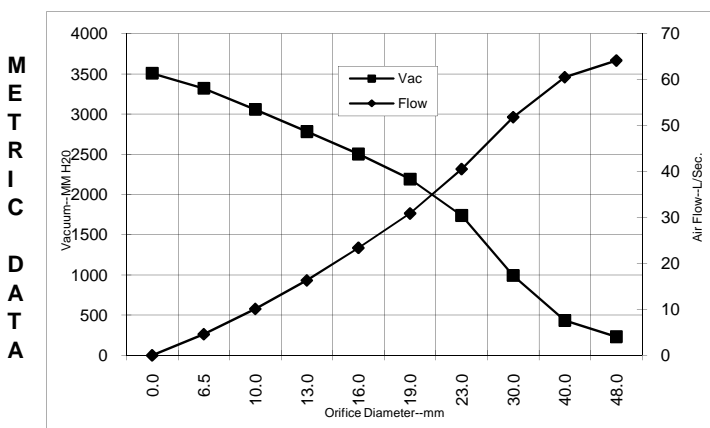

Orifice (mm)	Amps	Watts (In)	RPM	Vac (mm H <sub>2</sub> O)	Flow (L/Sec)	Air Watts
48.0	14.5	1674	24561	231	64.2	143
40.0	14.4	1663	24568	432	60.5	254
30.0	14.3	1652	24777	992	51.8	500
23.0	13.8	1599	25228	1739	40.5	684
19.0	13.0	1502	25988	2191	30.9	662
16.0	12.1	1409	26842	2504	23.4	572
13.0	19.1	1290	28049	2782	16.3	443
10.0	11.2	1156	29482	3058	10.1	301
6.5	8.8	1038	30992	3321	4.6	149
0.0	8.0	952	32499	3508	0.0	0

Note: Metric Performance data is calculated from the ASTM data above.

\* Data represents performance of a typical motor sampled from a large production quantity. Individual motor data may vary due to normal manufacturing variations.

Test Specs:	120 volts	Minimum Sealed Vacuum:	136.0	ORIFICE:	7/8 "	Minimum Vacuum:	64.0	Maximum Watts:	1590
-------------	-----------	------------------------	-------	----------	-------	-----------------	------	----------------	------



DIMENSIONS

NOTES:

1. MODEL NUMBER, DATE OF MANUFACTURE, PLANT LOCATION CODE, AGENCY RECOGNITION CODE, INSPECTOR'S CODE, MANUFACTURER'S NAME, "US PATENT: US 6,703,754 B1", VOLTAGE AND FREQUENCY, "08B ARM, 02F FLD" AND CUSTOMER'S PART NO. TO APPEAR ON MOTOR.
2. MOUNTING MUST NOT RESTRICT THIS DIAMETER.
3. GROUNDING OR EARTHING PROVISIONS: USE HOLES AS INDICATED FOR GROUNDING OR EARTHING. REFER TO APPROPRIATE LISTING OR REGULATORY AGENCY FOR PROPER METHOD OF GROUNDING OR EARTHING.

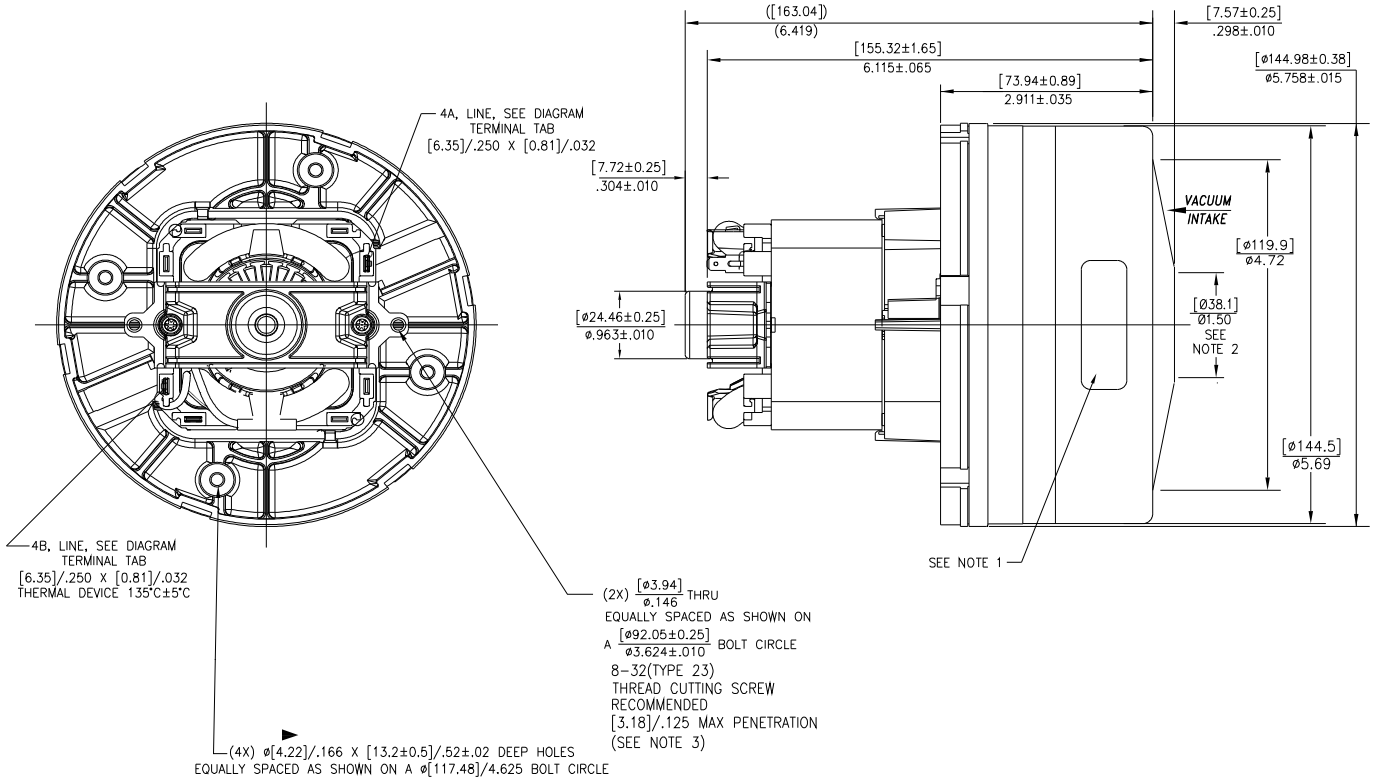

**Advantek III - Ultra II**

**IMPORTANT NOTE:** Pictorial and dimensional data are subject to change without notice. Contact factory for current revision levels.

**WARNING** - When using AMETEK Floorcare & Specialty Motors (F&SM) bypass motors in machines that come in contact with foam, liquid (including water), or other foreign substances, the machine must be designed and constructed to prevent those substances from reaching the fan system, motor housing, and electrical components. F&SM vacuum motors other than hazardous duty models should not be applied in machines that come in contact with dry chemicals or other volatile materials. Failure to observe these precautions could cause flashing (depending on volatility) or electrical shock which could result in property damage and severe bodily injury, including death in extreme cases. All applications incorporating F&SM motors should be submitted to appropriate organizations or agencies for testing specifically related to the safety of your equipment.

**AMETEK/Floorcare & Specialty Motors**  
**www.ametekfsm.com**