



Floorcare & Specialty Motors

Model: 122233-00

SPECIAL FEATURES

- 1500+ hours life (curved brush)
- 625 Peak Air Watts
- Up to 40% Overall Efficiency
- High efficient cooling system
- Lamb "Green Power Label"
- UL recognized, category PRGY2 (E47185)
- CSA certification pending
- Optional locked-rotor, blocked cooling air and running overload protection
- Optional new patent-pending bearing protection for wet applications.

DESCRIPTION

- 120 volts AC
- Two-stage tapered fan
- 6.6" / 162 mm diameter
- Improved sound quality
- "True" tangential discharge bracket
- High-Efficiency "Galaxy" lamination
- Double ball bearings; 10mm output

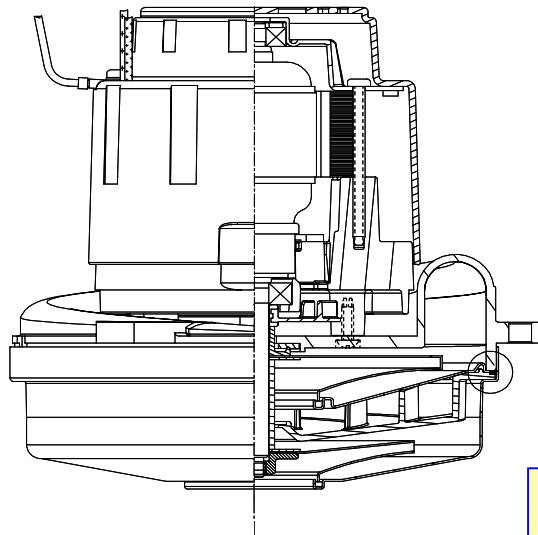

DESIGN APPLICATION

- Commercial and Residential Central Cleaning Systems
- Car wash vac and blower systems
- Equipment operating in environments requiring separation of working air from motor ventilating air
- Designed to handle clean, dry, filtered air only

PRELIMINARY BULLETIN

PEAK AIRWATTS

625

Calculated in accordance with ASTM F2105

TYPICAL MOTOR PERFORMANCE.*

(At 120 volts, 60Hz, test data is corrected to standard conditions of 29.92 Hg, 68° F.)

ASTM DATA

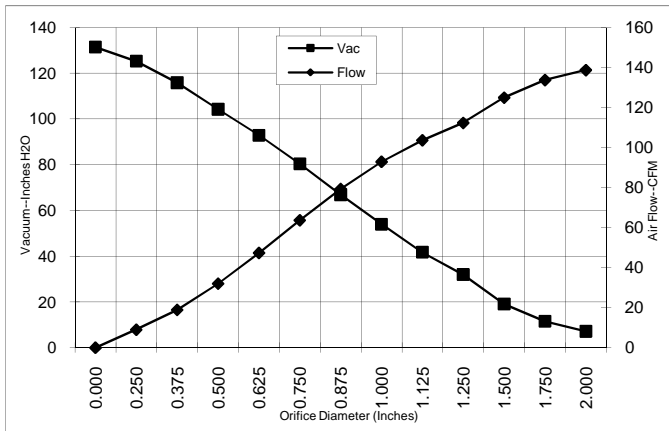

Orifice (Inches)	Amps	Watts (In)	RPM	Vac (In.H2O)	Flow (CFM)	Air Watts
2.000	14.0	1603	13069	7.1	138.8	115
1.750	13.9	1594	23070	11.5	133.8	181
1.500	13.9	1594	23025	19.1	125.0	280
1.250	13.8	1587	23113	32.0	112.4	422
1.125	13.7	1579	23163	41.8	103.7	508
1.000	13.8	1587	23165	54.0	92.9	588
0.875	13.7	1570	23259	66.9	79.3	623
0.750	13.2	1516	23683	80.4	63.7	601
0.625	12.3	1422	24309	92.9	47.4	516
0.500	11.2	1298	25331	104.3	32.0	392
0.375	9.9	1150	26700	115.9	18.9	258
0.250	9.1	1060	27995	125.3	9.0	133
0.000	8.2	966	29331	131.5	0.0	0

METRIC DATA

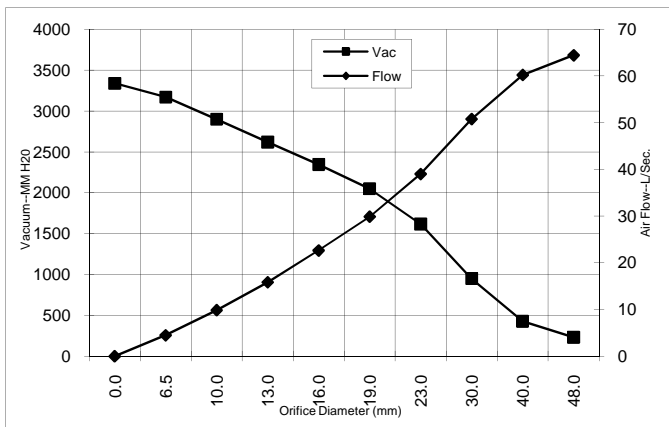

Orifice (mm)	Amps	Watts (In)	RPM	Vac (mm H2O)	Flow (L/Sec)	Air Watts
48.0	13.9	1599	17469	230	64.5	144
40.0	13.9	1594	23039	427	60.2	250
30.0	13.8	1582	23141	949	50.8	469
23.0	13.7	1574	23236	1617	39.0	614
19.0	13.2	1514	23696	2049	29.9	599
16.0	12.4	1426	24284	2346	22.7	519
13.0	11.3	1310	25229	2619	15.8	404
10.0	10.1	1172	26495	2899	9.9	278
6.5	9.1	1064	27930	3171	4.5	139
0.0	8.2	966	29331	3339	0.0	0

Note: Metric Performance data is calculated from the ASTM data above.

* Data represents performance of a typical motor sampled from a large production quantity. Individual motor data may vary due to normal manufacturing variations.

Test Specs:	120-Volts	Minimum Sealed Vacuum:	120.0	ORIFICE:	7/8"	Min. Vacuum:	62.0	Maximum Watts:	1680
--------------------	-----------	-------------------------------	-------	-----------------	------	---------------------	------	-----------------------	------

DIMENSIONS

- NOTES:
 1. LEADS: 18GA. STRANDED, POWER LEADS BLACK, GROUNDING LEAD GREEN OR GREEN WITH YELLOW STRIPE.
 2. MOTOR IDENTIFICATION: MANUFACTURER'S NAME, MODEL NUMBER, VOLTAGE, FREQUENCY, INSPECTORS CODE WITH "FF" SUFFIX, DATE OF MANUFACTURE, AGENCY RECOGNITION CODE, PLANT LOCATION CODE, PATENT PENDING AND COUNTRY OF ORIGIN.
 3. MOUNTING MUST NOT RESTRICT THIS DIAMETER.
 4. ALLOW [0.0026 SQ M]/4.0 SQ IN. (MIN.) FOR COOLING AIR INTAKE.
 5. COOLING AIR INTAKE MUST BE SEPARATED FROM COOLING AIR EXHAUST.
 6. COOLING AIR EXHAUST MUST BE SEPARATED FROM VACUUM EXHAUST.

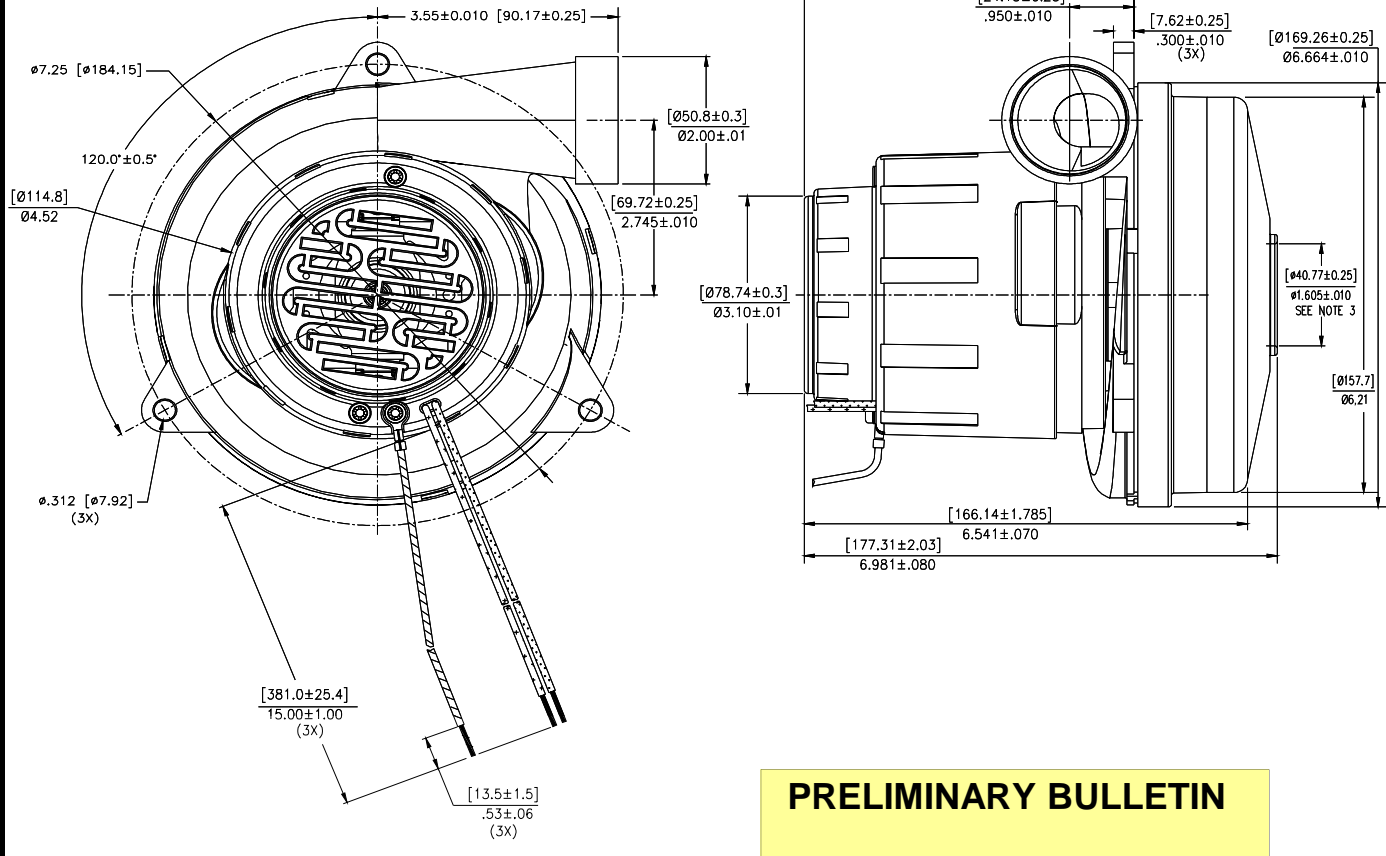

IMPORTANT NOTE: Pictorial and dimensional data are subject to change without notice. Contact factory for current revision levels.

WARNING - When using AMETEK Floorcare & Specialty Motors (F&SM) bypass motors in machines that come in contact with foam, liquid (including water), or other foreign substances, the machine must be designed and constructed to prevent those substances from reaching the fan system, motor housing, and electrical components. F&SM vacuum motors other than hazardous duty models should not be applied in machines that come in contact with dry chemicals or other volatile materials. Failure to observe these precautions could cause flashing (depending on volatility) or electrical shock which could result in property damage and severe bodily injury, including death in extreme cases. All applications incorporating F&SM motors should be submitted to appropriate organizations or agencies for testing specifically related to the safety of your equipment.

AMETEK/Floorcare & Specialty Motors
www.ametekfsm.com

Issued: June, 2009