



Floorcare & Specialty Motors

Model: 122232-18

SPECIAL FEATURES

- 2000+ hours life
- High efficient cooling system
- Lamb "Green Power Label"
- UL recognized, category PRGY2 (E47185)
- CSA certification pending
- Patent-pending bearing protection for wet applications.

DESCRIPTION

- 36 volts DC
- Single stage tapered fan
- 6.6" / 162 mm diameter
- Improved sound quality
- "True" tangential discharge bracket
- High-Efficiency "Galaxy" lamination
- Double ball bearings; 10mm output

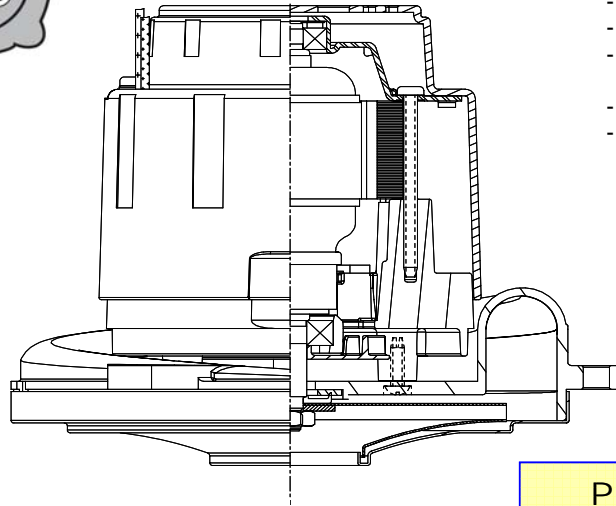

DESIGN APPLICATION

- Equipment operating in environments requiring separation of working air from motor ventilating air
- Designed to handle clean, dry, filtered air only

PEAK AIRWATTS

246

Calculated in accordance with ASTM F2105

TYPICAL MOTOR PERFORMANCE.*

(At 36 VDC, test data is corrected to standard conditions of 29.92 Hg, 68° F.)

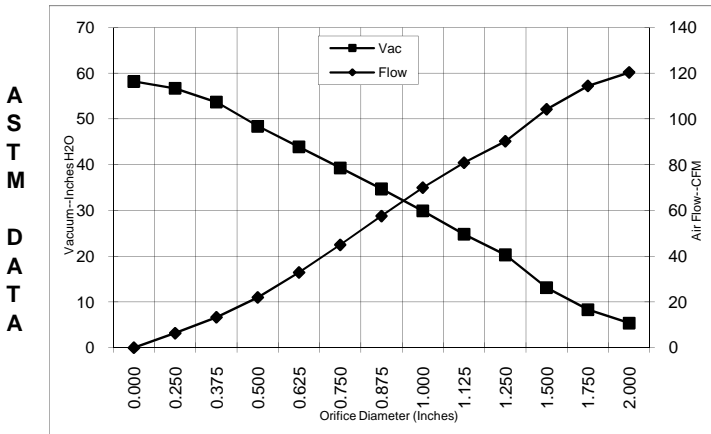

Orifice (Inches)	Amps	Watts (In)	RPM	Vac (In.H2O)	Flow (CFM)	Air Watts
2.000	19.4	700	18230	5.4	120.4	76
1.750	19.4	701	18220	8.3	114.5	112
1.500	19.4	700	18235	13.1	104.3	161
1.250	19.2	693	18370	20.3	90.3	215
1.125	18.9	684	18485	24.8	80.9	236
1.000	18.6	670	18740	29.9	70.0	246
0.875	17.9	647	19085	34.7	57.6	235
0.750	17.1	619	19505	39.3	45.0	208
0.625	16.2	585	20215	43.9	32.9	170
0.500	15.1	544	21065	48.4	22.0	125
0.375	14.1	509	22030	53.7	13.3	84
0.250	13.1	474	22845	56.7	6.4	43
0.000	12.4	448	23555	58.2	0.0	0

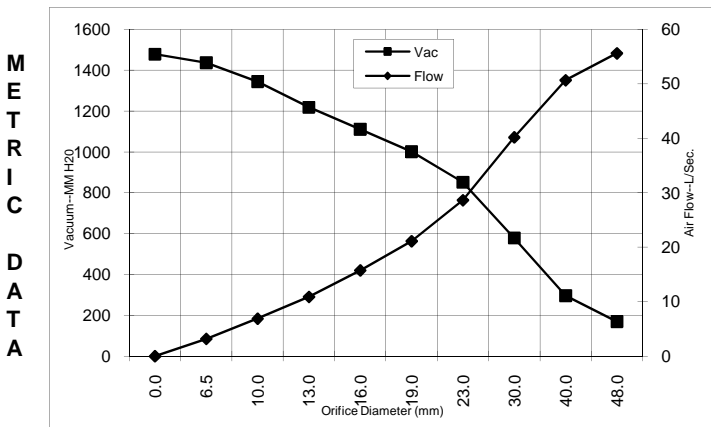

Orifice (mm)	Amps	Watts (In)	RPM	Vac (mm H2O)	Flow (L/Sec)	Air Watts
48.0	19.4	700	18226	169	55.6	92
40.0	19.4	700	18231	296	50.7	146
30.0	19.0	688	18433	578	40.2	227
23.0	18.0	653	18999	851	28.7	238
19.0	17.1	618	19519	1001	21.1	207
16.0	16.2	586	20187	1110	15.8	172
13.0	15.2	548	20980	1218	10.9	130
10.0	14.2	514	21885	1344	6.9	90
6.5	13.2	476	22804	1436	3.2	45
0.0	12.4	448	23555	1478	0.0	0

Note: Metric Performance data is calculated from the ASTM data above.

* Data represents performance of a typical motor sampled from a large production quantity. Individual motor data may vary due to normal manufacturing variations.

Test Specs:	36	Minimum Sealed Vacuum:	56.0	ORIFICE:	7/8"	Minimum Vacuum:	32.0	Maximum Watts:	690
--------------------	-----------	-------------------------------	-------------	-----------------	-------------	------------------------	-------------	-----------------------	------------

DIMENSIONS

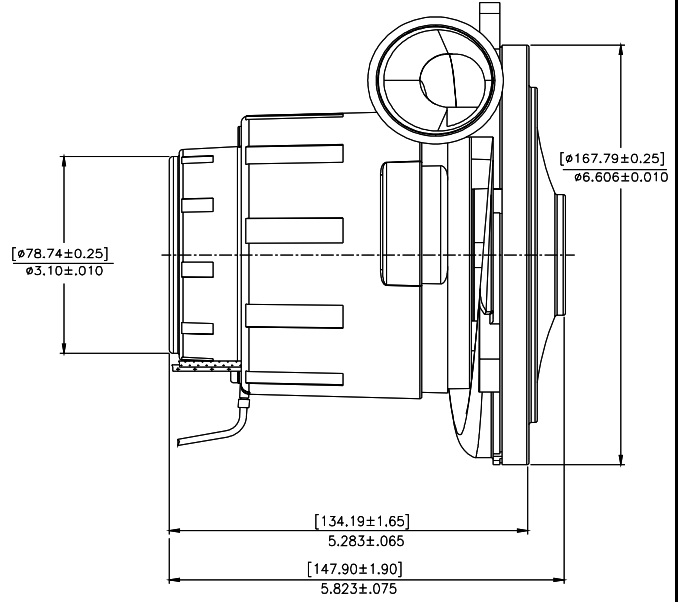
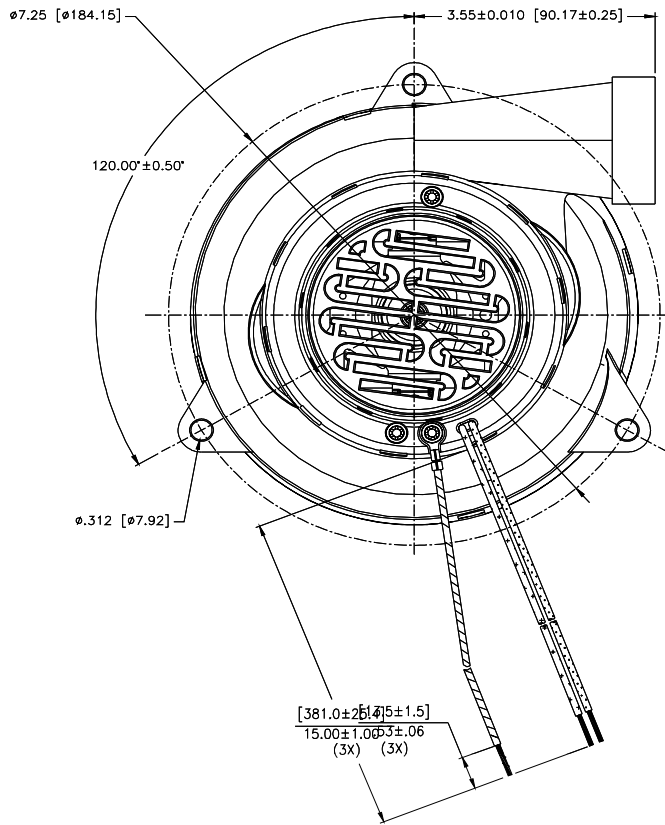

IMPORTANT NOTE: Pictorial and dimensional data are subject to change without notice. Contact factory for current revision levels.

WARNING - When using AMETEK Floorcare & Specialty Motors (F&SM) bypass motors in machines that come in contact with foam, liquid (including water), or other foreign substances, the machine must be designed and constructed to prevent those substances from reaching the fan system, motor housing, and electrical components. F&SM vacuum motors other than hazardous duty models should not be applied in machines that come in contact with dry chemicals or other volatile materials. Failure to observe these precautions could cause flashing (depending on volatility) or electrical shock which could result in property damage and severe bodily injury, including death in extreme cases. All applications incorporating F&SM motors should be submitted to appropriate organizations or agencies for testing specifically related to the safety of your equipment.

AMETEK/Floorcare & Specialty Motors
www.ametekfsm.com

Issued: October, 2009