



Model: 122171-07

DESCRIPTION

- Single stage tapered fan
- 8.4" / 213 mm diameter
- Improved sound quality
- "True" tangential discharge bracket
- 120 volts AC
- 3.5" High-Efficiency lamination
- Double ball bearings; 10mm output

DESIGN APPLICATION

- Commercial and Residential Central Cleaning Systems
- Car wash vac and blower systems
- Equipment operating in environments requiring separation of working air from motor ventilating air
- Designed to handle clean, dry, filtered air only

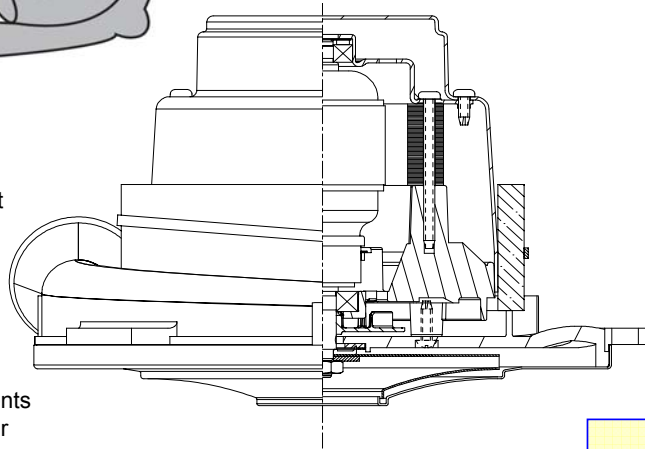

SPECIAL FEATURES

- 1500+ hours life (Infinity Brush)
- 700 Peak Air Watts
- Up to 45% Overall Efficiency
- High efficient cooling system
- Lamb "Green Power Label"
- UL recognized, category PRGY2 (E47185)
- CSA certification pending
- Same mounting patern as Lamb's 7.2 tangential-bypass
- With larger cooling fan and filter
- Optional locked-rotor, blocked cooling air and running overload protection
- Optional new patent-pending bearing protection for wet applications. (122170-18)

PEAK AIRWATTS

717

Calculated in accordance with ASTM F2105

TYPICAL MOTOR PERFORMANCE.*

(At 120 volts, 60Hz, test data is corrected to standard conditions of 29.92 Hg, 68° F.)

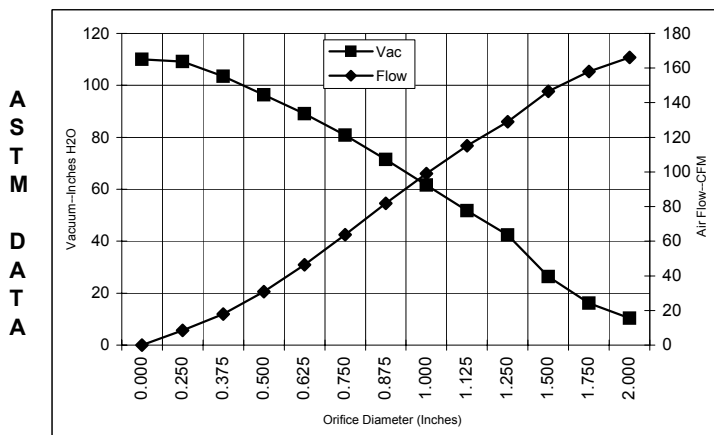

Orifice (Inches)	Amps	Watts (In)	RPM	Vac (In.H ₂ O)	Flow (CFM)	Air Watts
2.000	15.1	1718	26120	10.4	166.2	204
1.750	15.1	1715	26120	16.2	158.0	302
1.500	15.0	1703	26120	26.4	146.6	455
1.250	14.8	1681	26510	42.4	129.0	643
1.125	14.4	1645	26520	51.8	115.1	700
1.000	14.0	1600	26910	61.6	99.0	716
0.875	13.4	1528	27690	71.4	81.9	687
0.750	12.5	1437	28520	80.8	63.8	606
0.625	11.5	1320	29680	89.1	46.4	486
0.500	10.5	1212	30870	96.3	30.8	348
0.375	9.7	1124	32050	103.5	18.0	219
0.250	9.0	1047	33250	109.1	8.5	109
0.000	8.5	968	3420	110.0	0.0	0

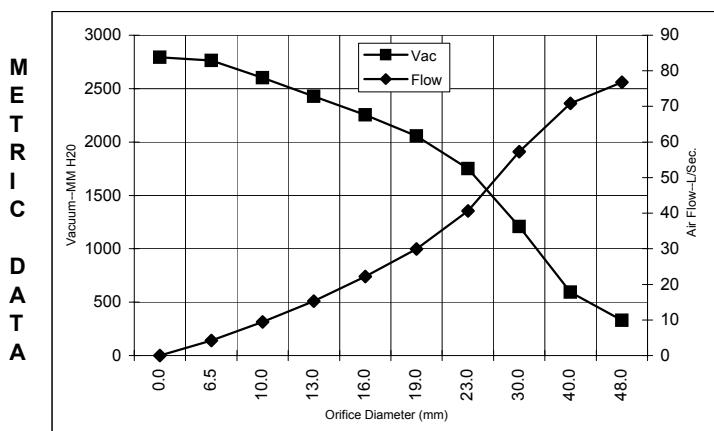

Orifice (mm)	Amps	Watts (In)	RPM	Vac (mm H ₂ O)	Flow (L/Sec)	Air Watts
48.0	15.1	1717	26120	329	76.7	247
40.0	15.0	1707	26120	593	70.8	409
30.0	14.6	1661	26516	1208	57.3	674
23.0	13.5	1546	27495	1751	40.7	694
19.0	12.5	1435	28543	2057	29.9	604
16.0	11.5	1325	29634	2255	22.2	491
13.0	10.6	1223	30751	2428	15.3	362
10.0	9.8	1137	31873	2601	9.4	238
6.5	9.0	1051	33190	2764	4.2	115
0.0	8.5	968	3420	2794	0.0	0

Note: Metric Performance data is calculated from the ASTM data above.

* Data represents performance of a typical motor sampled from a large production quantity. Individual motor data may vary due to normal manufacturing variations.

Test Specs:	120	Minimum Sealed Vacuum:	100"	ORIFICE:	7/8"	Minimum Vacuum:	65"	Maximum Watts:	1750
--------------------	-----	-------------------------------	------	-----------------	------	------------------------	-----	-----------------------	------

DIMENSIONS



NOTES:

1. LEADS: 16GA. STRANDED, BLACK.
2. MOTOR IDENTIFICATION: MANUFACTURER'S NAME, MODEL NUMBER, VOLTAGE, FREQUENCY, INSPECTORS CODE WITH "FF" SUFFIX, DATE OF MANUFACTURE, AGENCY RECOGNITION CODE, PLANT LOCATION CODE, PATENT PENDING AND COUNTRY OF ORIGIN.
3. MOUNTING MUST NOT RESTRICT THIS DIAMETER.
4. ALLOW [0.0026 SQ M]/4.0 SQ IN. (MIN.) FOR COOLING AIR INTAKE.
5. COOLING AIR INTAKE MUST BE SEPARATED FROM COOLING AIR EXHAUST.
6. COOLING AIR EXHAUST MUST BE SEPARATED FROM VACUUM EXHAUST.

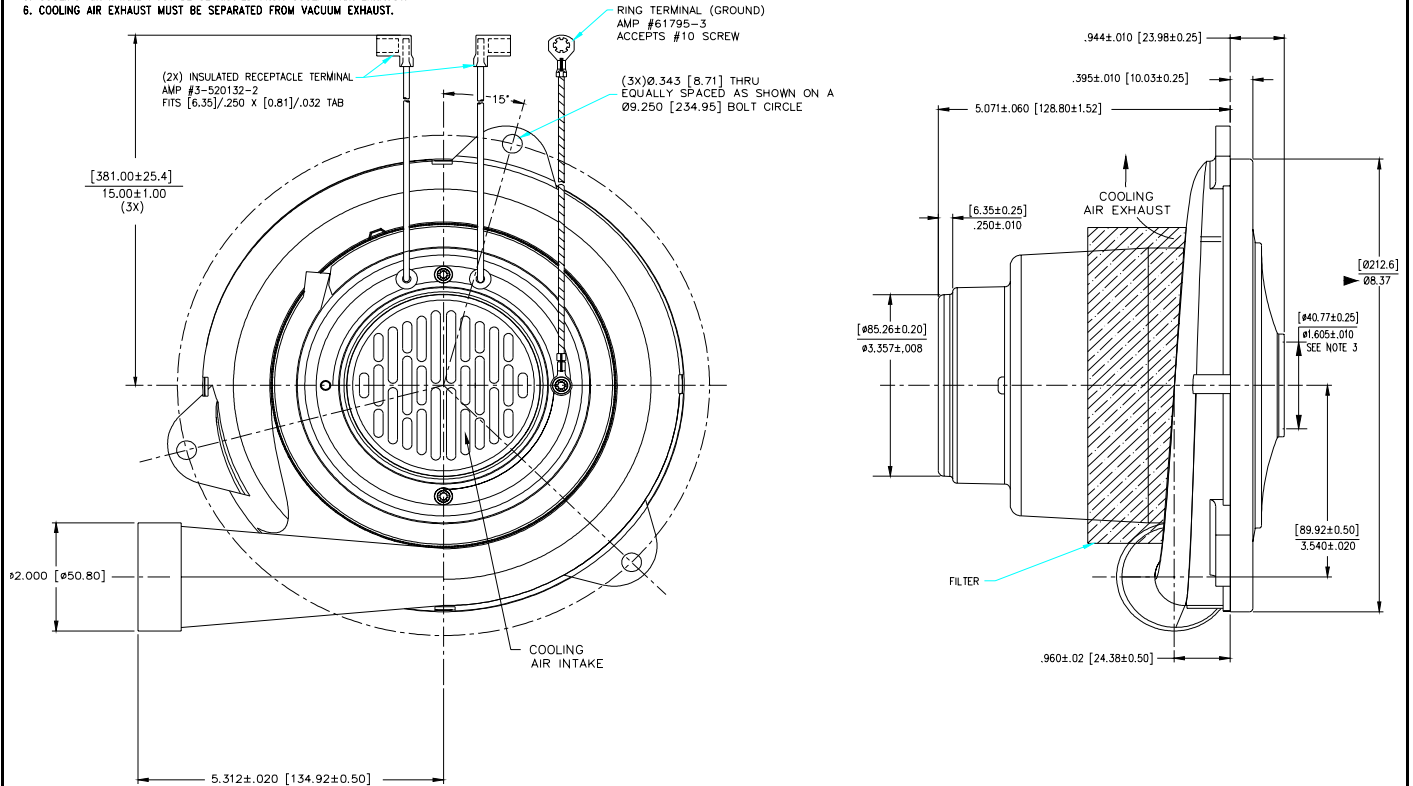

IMPORTANT NOTE: Pictorial and dimensional data are subject to change without notice. Contact factory for current revision levels.

WARNING - When using AMETEK Floorcare & Specialty Motors (F&SM) bypass motors in machines that come in contact with foam, liquid (including water), or other foreign substances, the machine must be designed and constructed to prevent those substances from reaching the fan system, motor housing, and electrical components. F&SM vacuum motors other than hazardous duty models should not be applied in machines that come in contact with dry chemicals or other volatile materials. Failure to observe these precautions could cause flashing (depending on volatility) or electrical shock which could result in property damage and severe bodily injury, including death in extreme cases. All applications incorporating F&SM motors should be submitted to appropriate organizations or agencies for testing specifically related to the safety of your equipment.

AMETEK/Floorcare & Specialty Motors
www.ametekfsm.com