



LAMB ELECTRIC

Model: 122094-00

Eco Design
Compact -- Energy Saving

SPECIAL FEATURES

DESCRIPTION

- One stage
- 4.73"/120 mm diameter
- Double ball bearings
- Single speed
- Thru-flow discharge
- Thermoset fan end bracket
- Stamped steel end bracket

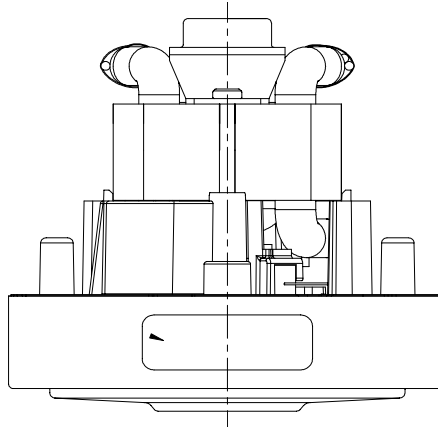

- Patented High Efficiency Diffusion
- 44% Overall Efficiency
- WL - World Lamination
- Single Stage
- UL recognized, category PRGY2 (E47185)
- Suitable for 120 volt AC operation, 50 or 60 Hz

DESIGN APPLICATION

- Equipment operating in environments not requiring separation of working air from motor ventilating air
- Designed to handle clean, dry, filtered air only

PEAK AIRWATTS
540
Calculated in accordance with ASTM F2105

TYPICAL MOTOR PERFORMANCE.*

(At 120 volts, 60Hz, test data is corrected to standard conditions of 29.92 Hg, 68° F.)

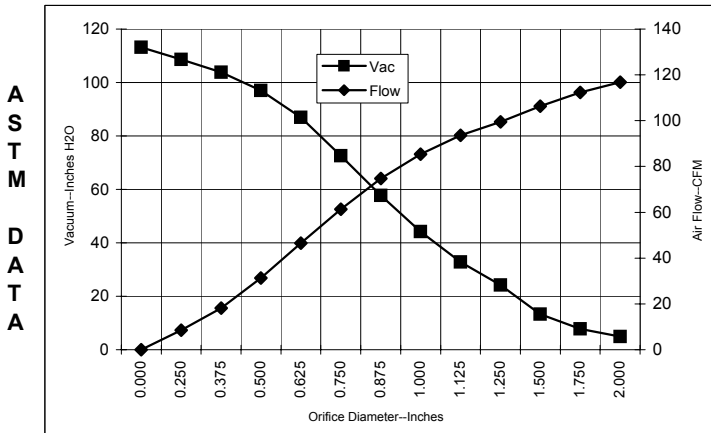

Orifice (Inches)	Amps	Watts (In)	RPM	Vac (In.H2O)	Flow (CFM)	Air Watts
2.000	12.1	1416	34044	4.9	116.8	69
1.750	12.0	1406	34142	7.8	112.4	106
1.500	11.9	1398	34339	13.3	106.4	171
1.250	11.7	1374	34630	24.1	99.5	290
1.125	11.5	1353	34925	32.8	93.6	370
1.000	11.2	1318	35413	44.2	85.4	455
0.875	10.8	1269	36158	57.8	74.8	521
0.750	10.3	1208	37133	72.6	61.4	538
0.625	9.7	1138	38452	87.0	46.5	487
0.500	8.9	1054	40065	97.0	31.3	367
0.375	8.3	984	41528	103.8	18.2	228
0.250	7.9	930	42827	108.7	8.6	112
0.000	7.3	864	44794	113.2	0.0	0

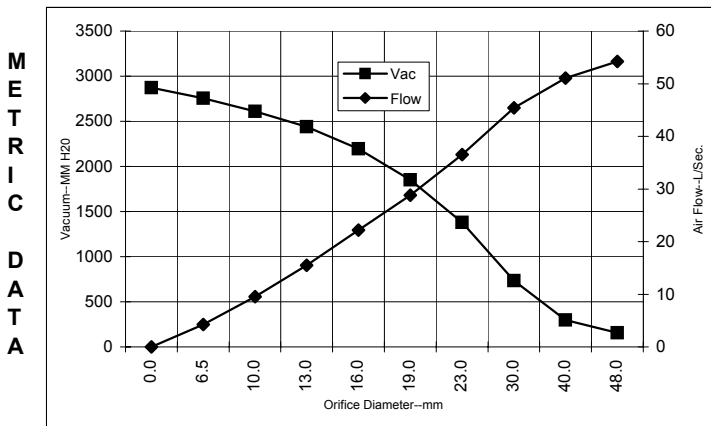

Orifice (mm)	Amps	Watts (In)	RPM	Vac (mm H2O)	Flow (L/Sec)	Air Watts
48.0	12.1	1411	34087	157	54.2	85
40.0	12.0	1400	34280	296	51.1	151
30.0	11.6	1362	34792	734	45.4	334
23.0	10.9	1281	35971	1380	36.6	504
19.0	10.3	1207	37159	1852	28.8	537
16.0	9.7	1141	38399	2194	22.2	489
13.0	9.0	1063	39904	2439	15.5	379
10.0	8.4	995	41309	2611	9.5	249
6.5	7.9	933	42762	2754	4.3	118
0.0	7.3	864	44794	2874	0.0	0

Note: Metric Performance data is calculated from the ASTM data above.

* Data represents performance of a typical motor sampled from a large production quantity. Individual motor data may vary due to normal manufacturing variations.

Test Specs: 120 volts	Minimum Sealed Vacuum: 112.0	ORIFICE: 7/8 "	Minimum Vacuum: 54.0	Maximum Watts: 1390
------------------------------	-------------------------------------	-----------------------	-----------------------------	----------------------------

DIMENSIONS

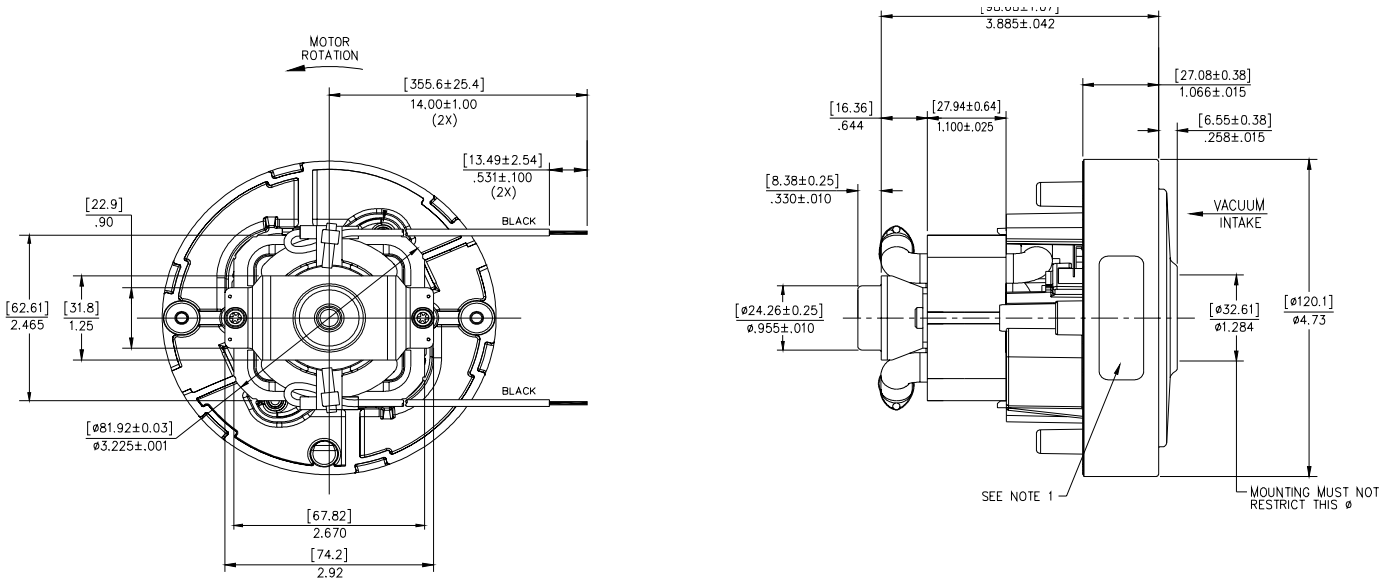

IMPORTANT NOTE: Pictorial and dimensional data are subject to change without notice. Contact factory for current revision levels.

WARNING - AMETEK Lamb Electric thru-flow vacuum motors must never be used in applications in which wet or moist conditions are involved, where dry chemicals or other volatile materials are present, or where airflow may be restricted or blocked. Such motors are designed to permit the vacuumed air to pass over the electrical winding to cool it. Thus any foam, liquid (including water), dry chemical, or other foreign substance coming in contact with electrical conductors could cause combustion (depending on volatility) or electrical shock. Failure to observe these precautions could result in property damage and severe personal injury, including death in extreme cases. All applications incorporating Lamb Electric motors should be submitted to Underwriters Laboratories Inc. or other appropriate organizations or agencies for testing specifically related to the safety of your equipment.

AMETEK/Lamb Electric Division
 627 Lake Street
 Kent, Ohio 44240
 U.S.A.
 Tel: (330) 673-3451 Fax: (330) 673-8994
 www.lambelectric.com