



LAMB ELECTRIC

Model: 122050-00

DESCRIPTION

- Five stage Fan system
- 120 volts
- 5.7"/145 mm diameter
- Double ball bearings
- Single speed
- Tangential bypass discharge

DESIGN APPLICATION

- Equipment operating in environments requiring separation of working air from motor ventilating air
- Designed to handle clean, dry, filtered air only

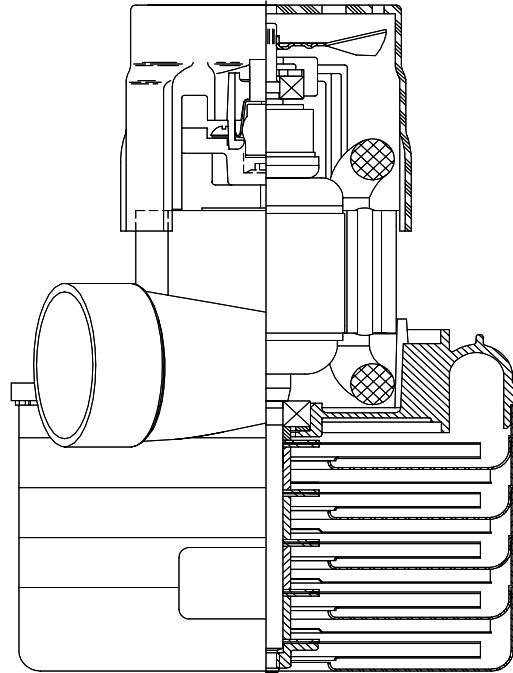

SPECIAL FEATURES

- Suitable for 120 volt AC operation, 50/60 Hz
- UL recognized, category PRGY2 (E47185)
- Provision for grounding
- Open frame design
- Aluminum fan-end bracket designed to dampen vibration and improve durability
- 10 mm shaft and bearing system
- Special fans designed for high pressure/low volume operation
- The Lamb Electric vacuum motor line offers a wide range of performance levels to meet design needs

TYPICAL MOTOR PERFORMANCE.*

(At 120 volts, 60Hz, test data is corrected to standard conditions of 29.92 Hg, 68° F.)

ASTM DATA

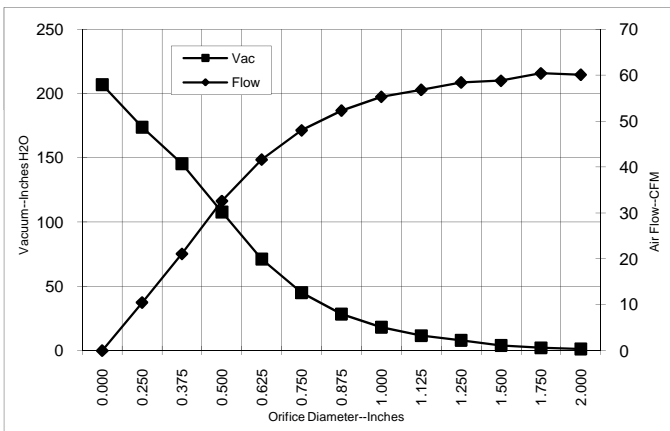

Orifice (Inches)	Amps	Watts (In)	RPM	Vac (In.H2O)	Flow (CFM)	Air Watts
2.000	14.2	1615	20490	1.3	60.1	9
1.750	14.2	1611	20440	2.2	60.4	16
1.500	14.2	1610	20410	4.0	58.8	28
1.250	14.2	1607	20440	8.1	58.4	56
1.125	14.2	1603	20400	11.7	56.8	78
1.000	14.2	1610	20390	18.2	55.3	118
0.875	14.2	1615	23360	28.5	52.3	175
0.750	14.2	1610	20340	45.1	48.0	254
0.625	14.1	1597	20430	71.2	41.6	348
0.500	13.8	1572	20630	107.8	32.6	413
0.375	12.9	1469	21270	145.4	21.1	360
0.250	11.4	1303	22590	173.7	10.5	214
0.000	9.4	1092	24620	206.8	0.0	0

METRIC DATA

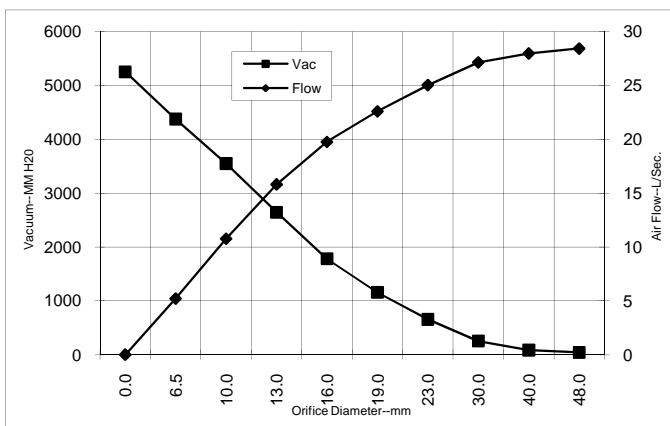

Orifice (mm)	Amps	Watts (In)	RPM	Vac (mm H2O)	Flow (L/Sec)	Air Watts
48.0	14.2	1613	20468	43	28.4	12
40.0	14.2	1610	20419	88	28.0	24
30.0	14.2	1605	20418	256	27.1	68
23.0	14.2	1614	22618	658	25.0	161
19.0	14.2	1610	20342	1159	22.6	256
16.0	14.1	1598	20426	1782	19.8	344
13.0	13.9	1575	20610	2645	15.8	407
10.0	13.0	1484	21174	3550	10.8	368
6.5	11.4	1311	22524	4376	5.2	221
0.0	9.4	1092	24620	5253	0.0	0

Note: Metric performance data is calculated from the ASTM data above.

* Data represents performance of a typical motor sampled from a large production quantity. Individual motor data may vary due to normal manufacturing variations.

Test Specs:	120 volts	Minimum Sealed Vacuum:	TBD	ORIFICE:	13mm	Minimum Vacuum:	TBD	Maximum Watts:	TBD
-------------	-----------	------------------------	-----	----------	------	-----------------	-----	----------------	-----

DIMENSIONS

NOTES:

1. LEADS: 18GA STRANDED. LEADS CAN BE ANY COLOR EXCEPT GREEN OR GREEN WITH YELLOW STRIPE.
2. GROUNDING OR EARTHING PROVISIONS: USE HOLES AS INDICATED FOR GROUNDING OR EARTHING. REFER TO APPROPRIATE LISTING OR REGULATORY AGENCY FOR PROPER METHOD OF GROUNDING OR EARTHING.
3. MOTOR IDENTIFICATION: MANUFACTURER'S NAME, MODEL NUMBER, VOLTAGE, FREQUENCY, INSPECTION CODE WITH "F" SUFFIX, DATE OF MANUFACTURE, AGENCY RECOGNITION CODE, PLANT LOCATION CODE, PATENT INFORMATION "ONE OR MORE OF THE FOLLOWING PATENTS APPLY TO THIS MOTOR: 5482378; 5736805; 4669952; 4684835". AND COUNTRY OF ORIGIN.
4. ALLOW [0.0016 SQ M]/2.5 SQ IN. FOR COOLING AIR INTAKE.
5. COOLING AIR INTAKE MUST BE SEPARATED FROM COOLING AIR EXHAUST.
6. COOLING AIR EXHAUST MUST BE SEPARATED FROM VACUUM AIR EXHAUST.
7. MOUNTING MUST NOT RESTRICT THIS DIAMETER.

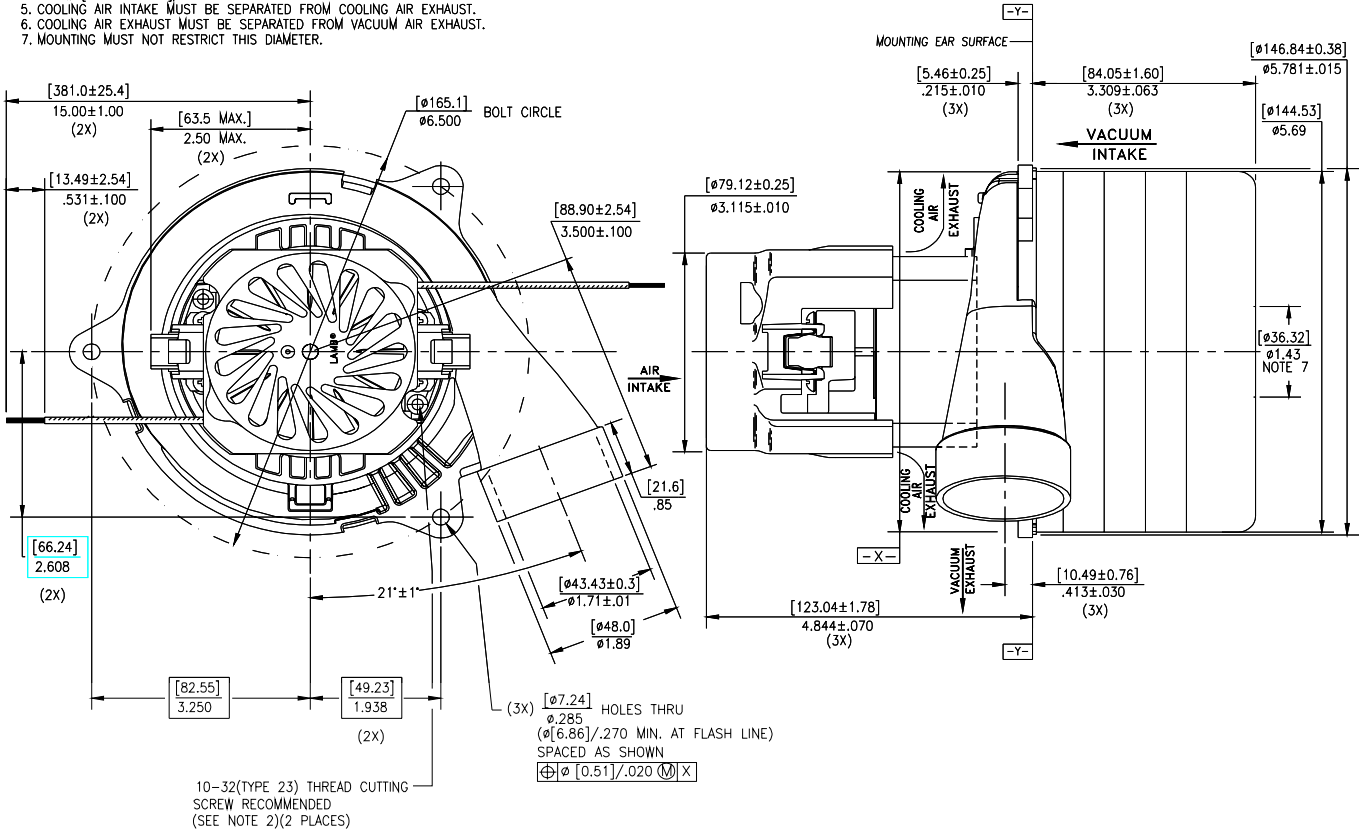

IMPORTANT NOTE: Pictorial and dimensional data are subject to change without notice. Contact factory for current revision levels.

WARNING - When using AMETEK Lamb Electric bypass motors in machines that come in contact with foam, liquid (including water), or other foreign substances, the machine must be designed and constructed to prevent those substances from reaching the fan system, motor housing, and electrical components. Lamb Electric vacuum motors other than hazardous duty models should not be applied in machines that come in contact with dry chemicals or other volatile materials. Failure to observe these precautions could cause flashing (depending on volatility) or electrical shock which could result in property damage and severe bodily injury, including death in extreme cases. All applications incorporating Lamb Electric motors should be submitted to appropriate organizations or agencies for testing specifically related to the safety of your equipment.

AMETEK/Lamb Electric Division
627 Lake Street
Kent, Ohio 44240
U.S.A.
Tel: (330) 673-3451 Fax: (330) 673-8994
www.lambelectric.com