



AMETEK

LAMB ELECTRIC

G2K

Generation 2000 Vacuum Motors

Product Bulletin

Model: 119891-06

DESCRIPTION

- Two stage
- 24 Volts
- 5.7"/145 mm diameter
- Double ball bearings
- Single speed
- Tangential bypass discharge
- Thermoset fan end bracket
- Thermoset commutator bracket

DESIGN APPLICATION

- Equipment operating in environments requiring separation of working air from motor ventilating air
- Designed to handle clean, dry, filtered air only

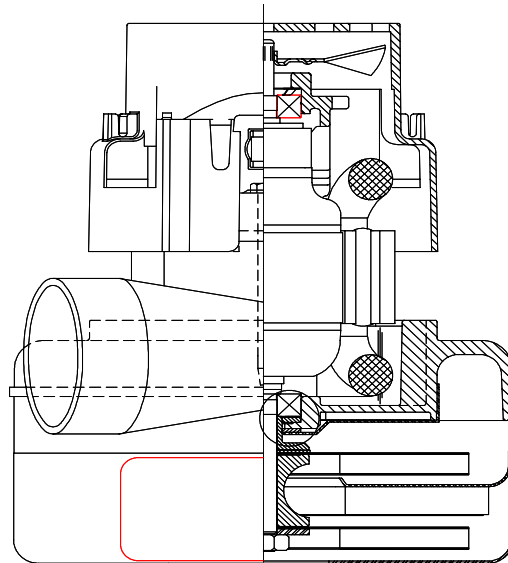

SPECIAL FEATURES

- Suitable for 24 volt DC operation
- UL Recognized, category PRGY2 (E47185)
- Provision for grounding
- Skeleton-frame design
- Epoxy painted fan case
- Patented air seal bearing construction. U.S. Patent #4,088,424
- The Lamb Electric vacuum motor line offers a wide range of performance levels to meet design needs.

TYPICAL MOTOR PERFORMANCE.*

(At 24 volts DC, test data is corrected to standard conditions of 29.92 Hg, 68° F.)

ASTM DATA

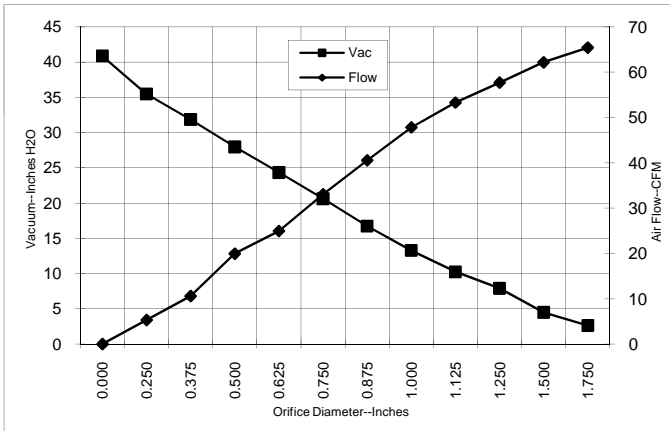

Orifice (Inches)	Amps	Watts (In)	RPM	Vac (In.H ₂ O)	Flow (CFM)	Air Watts
2.000	15.5	371	11727	1.6	66.3	12
1.750	14.5	371	11689	2.6	65.4	20
1.500	15.5	372	11620	4.5	62.2	33
1.250	15.6	374	11605	7.9	57.7	54
1.125	15.5	371	11637	10.3	53.3	64
1.000	15.2	366	11749	13.3	47.8	75
0.875	14.8	356	11969	16.7	40.6	80
0.750	14.3	342	12278	20.6	33.1	80
0.625	13.6	326	12708	24.3	25.0	72
0.500	12.8	308	13252	28.0	20.0	56
0.375	12.0	288	13915	31.8	10.6	40
0.250	11.3	272	14516	35.5	5.3	22
0.000	10.7	257	15208	40.9	0.0	0

METRIC DATA

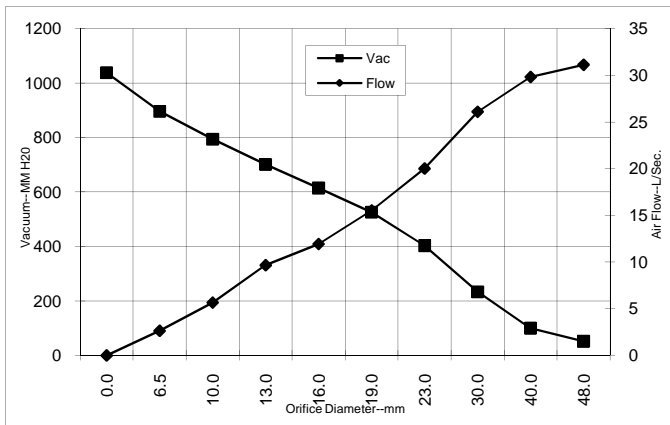

Orifice (mm)	Amps	Watts (In)	RPM	Vac (mm H ₂ O)	Flow (L/Sec)	Air Watts
48.0	15.0	371	11710	52	31.1	16
40.0	15.2	372	11641	100	29.8	29
30.0	15.5	372	11622	233	26.1	60
23.0	14.9	359	11914	403	20.0	79
19.0	14.2	342	12286	526	15.5	80
16.0	13.6	327	12690	614	11.9	72
13.0	12.9	310	13197	701	9.7	58
10.0	12.1	291	13815	794	5.7	42
6.5	11.4	273	14486	896	2.6	23
0.0	10.7	257	15208	1038	0.0	0

Note: Metric performance data is calculated from the ASTM data above.

* Data represents performance of a typical motor sampled from a large production quantity. Individual motor data may vary due to normal manufacturing variations.

Test Specs:	24 volts	Minimum Sealed Vacuum:	41.4"	ORIFICE:	7/8 "	Minimum Vacuum:	17.0"	Maximum Watts:	431
--------------------	----------	-------------------------------	-------	-----------------	-------	------------------------	-------	-----------------------	-----

DIMENSIONS



NOTES:

1. LEADS: 14GA STRANDED, LEADS CAN BE ANY COLOR EXCEPT GREEN OR GREEN WITH YELLOW STRIPE.
2. MOTOR IDENTIFICATION: MANUFACTURER'S NAME, MODEL NUMBER, VOLTAGE, FREQUENCY, INSPECTOR'S CODE WITH "JF" SUFFIX, DATE OF MANUFACTURE, AGENCY RECOGNITION CODE, PLANT LOCATION CODE, PATENT INFORMATION, ONE OR MORE OF THE FOLLOWING PATENTS APPLY TO THIS MOTOR: 6482378; 6736805; 4669952; 4684835; 6472786, AND COUNTRY OF ORIGIN.
3. ALLOW [0.0016 SQ. IN.]/2.5 SQ IN. MIN. FOR COOLING AIR INTAKE.
4. COOLING AIR INTAKE MUST BE SEPARATED FROM COOLING AIR EXHAUST.
5. VACUUM EXHAUST MUST BE SEPARATED FROM COOLING EXHAUST.
6. MOUNTING MUST NOT RESTRICT THIS DIAMETER.

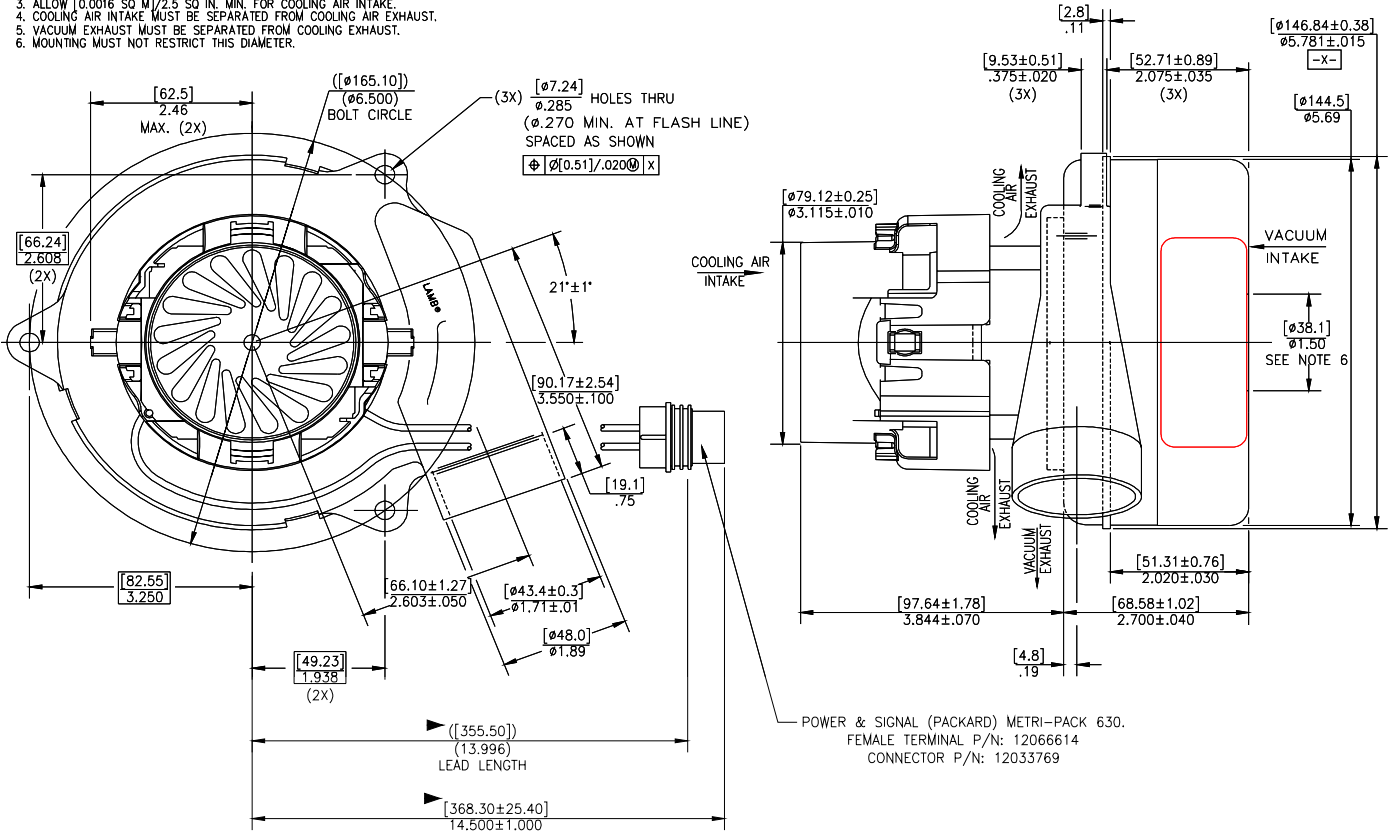

IMPORTANT NOTE: Pictorial and dimensional data are subject to change without notice. Contact factory for current revision levels.

WARNING - When using AMETEK Lamb Electric bypass motors in machines that come in contact with foam, liquid (including water), or other foreign substances, the machine must be designed and constructed to prevent those substances from reaching the fan system, motor housing, and electrical components. Lamb Electric vacuum motors other than hazardous duty models should not be applied in machines that come in contact with dry chemicals or other volatile materials. Failure to observe these precautions could cause flashing (depending on volatility) or electrical shock which could result in property damage and severe bodily injury, including death in extreme cases. All applications incorporating Lamb Electric motors should be submitted to appropriate organizations or agencies for testing specifically related to the safety of your equipment.

AMETEK/Floorcare & Specialty Motors Division
 627 Lake Street
 Kent, Ohio 44240
 U.S.A.
 Tel: (330) 673-3786 Fax: (330) 677-3812
 www.ametekfsm.com