



AMETEK
LAMB ELECTRIC

Product Bulletin

Model: 119679-07

DESCRIPTION

- Two stage
- 240 volts
- 5.7"/145 mm diameter
- Double ball bearings
- Single speed
- Tangential bypass discharge
- Aluminum fan end bracket
- Thermoset commutator bracket

DESIGN APPLICATION

- Equipment operating in environments requiring separation of working air from motor ventilating air.
- Designed to handle clean, dry, filtered air only.

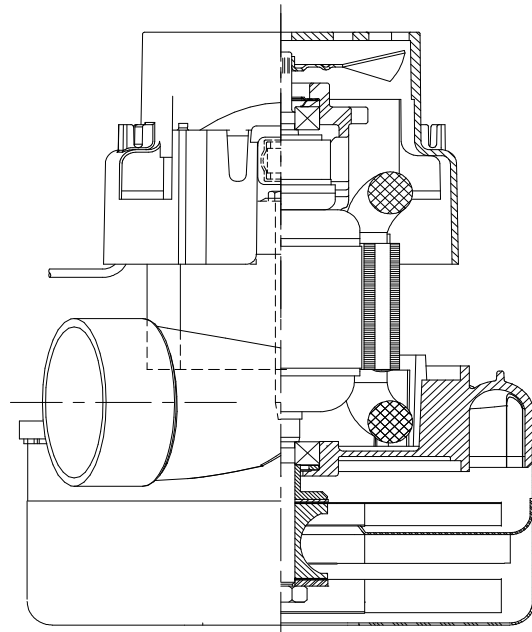

SPECIAL FEATURES

- Suitable for 240 volt AC operation, 50/60 Hz
- UL recognized, category PRGY2 (E47185)
- Provision for grounding
- Skeleton-frame design
- The Lamb Electric vacuum motor line offers a wide range of performance levels to meet design needs.

TYPICAL MOTOR PERFORMANCE.* (At 240 volts, 60Hz, test data is corrected to standard conditions of 29.92 Hg, 68°F.)

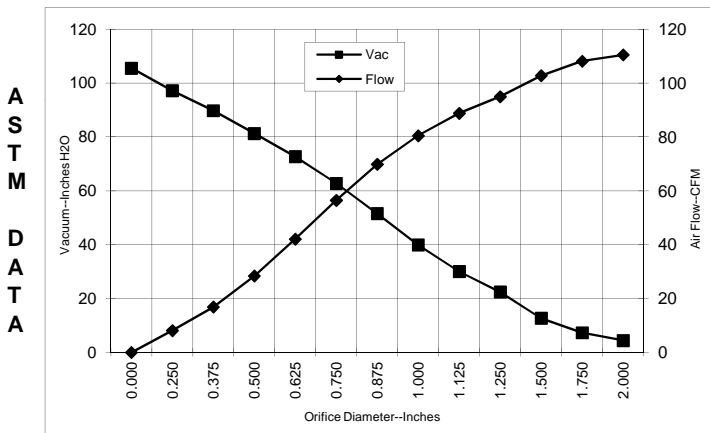

Orifice (Inches)	Amps	Watts (In)	RPM	Vac (In.H2O)	Flow (CFM)	Air Watts
2.000	6.4	1473	19,907	4.4	110.5	58
1.750	6.4	1471	19,907	7.3	108.1	94
1.500	6.4	1464	19,933	12.7	102.8	154
1.250	6.4	1453	20,046	22.4	95.0	250
1.125	6.3	1435	20,161	30.1	88.8	314
1.000	6.2	1419	20,305	39.9	80.5	377
0.875	6.1	1387	20,526	51.5	69.9	424
0.750	5.8	1336	20,943	62.8	56.5	417
0.625	5.5	1264	21,553	72.7	42.1	359
0.500	5.1	1181	22,314	81.3	28.4	271
0.375	4.8	1102	23,222	89.8	16.9	177
0.250	4.5	1035	24,014	97.2	8.1	93
0.000	4.2	983	24,713	105.5	0.0	0

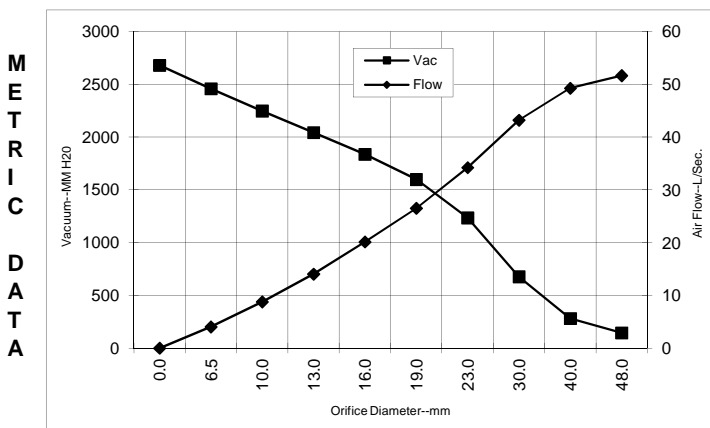

Orifice (mm)	Amps	Watts (In)	RPM	Vac (mm H2O)	Flow (L/Sec)	Air Watts
48.0	6.4	1472	19907	145	51.7	74
40.0	6.4	1466	19925	281	49.3	136
30.0	6.3	1443	20109	676	43.2	285
23.0	6.1	1395	20471	1235	34.2	412
19.0	5.8	1335	20955	1599	26.5	416
16.0	5.5	1267	21529	1837	20.1	362
13.0	5.2	1190	22238	2043	14.0	280
10.0	4.8	1114	23086	2247	8.8	192
6.5	4.5	1039	23974	2458	4.0	97
0.0	4.2	983	24713	2680	0.0	0

Note: Metric performance data is calculated from the ASTM data above.

* Data represents performance of a typical motor sampled from a large production quantity. Individual motor data may vary due to normal manufacturing variations.

Test Specs:	240 volts	Minimum Sealed Vacuum:	101.0"	ORIFICE:	7/8 "	Minimum Vacuum:	49.0"	Maximum Watts:	1470
--------------------	-----------	-------------------------------	--------	-----------------	-------	------------------------	-------	-----------------------	------

DIMENSIONS

NOTES:

1. POWER LEADS: 18GA STRANDED. LEADS CAN BE ANY COLOR EXCEPT GREEN OR GREEN WITH YELLOW STRIPE.
2. GROUND LEAD: 18 GA. STRANDED; COLOR: GREEN WITH YELLOW STRIPE.
3. MOTOR IDENTIFICATION: MANUFACTURER'S NAME, MODEL NUMBER, VOLTAGE, FREQUENCY, INSPECTORS CODE, DATE OF MANUFACTURE, AGENCY RECOGNITION CODE, PLANT LOCATION CODE, PATENT INFORMATION, "ONE OR MORE OF THE FOLLOWING PATENTS APPLY TO THIS MOTOR: 5482378; 5736805; 4669952; 4684835". AND MADE IN THE USA.
4. ALLOW 10.0016 SD M/2.5 SD IN. MIN. FOR COOLING AIR INTAKE.
5. COOLING AIR INTAKE MUST BE SEPERATED FROM COOLING AIR EXHAUST.
6. VACUUM EXHAUST MUST BE SEPERATED FROM COOLING EXHAUST.
7. MOUNTING MUST NOT RESTRICT THIS DIAMETER.

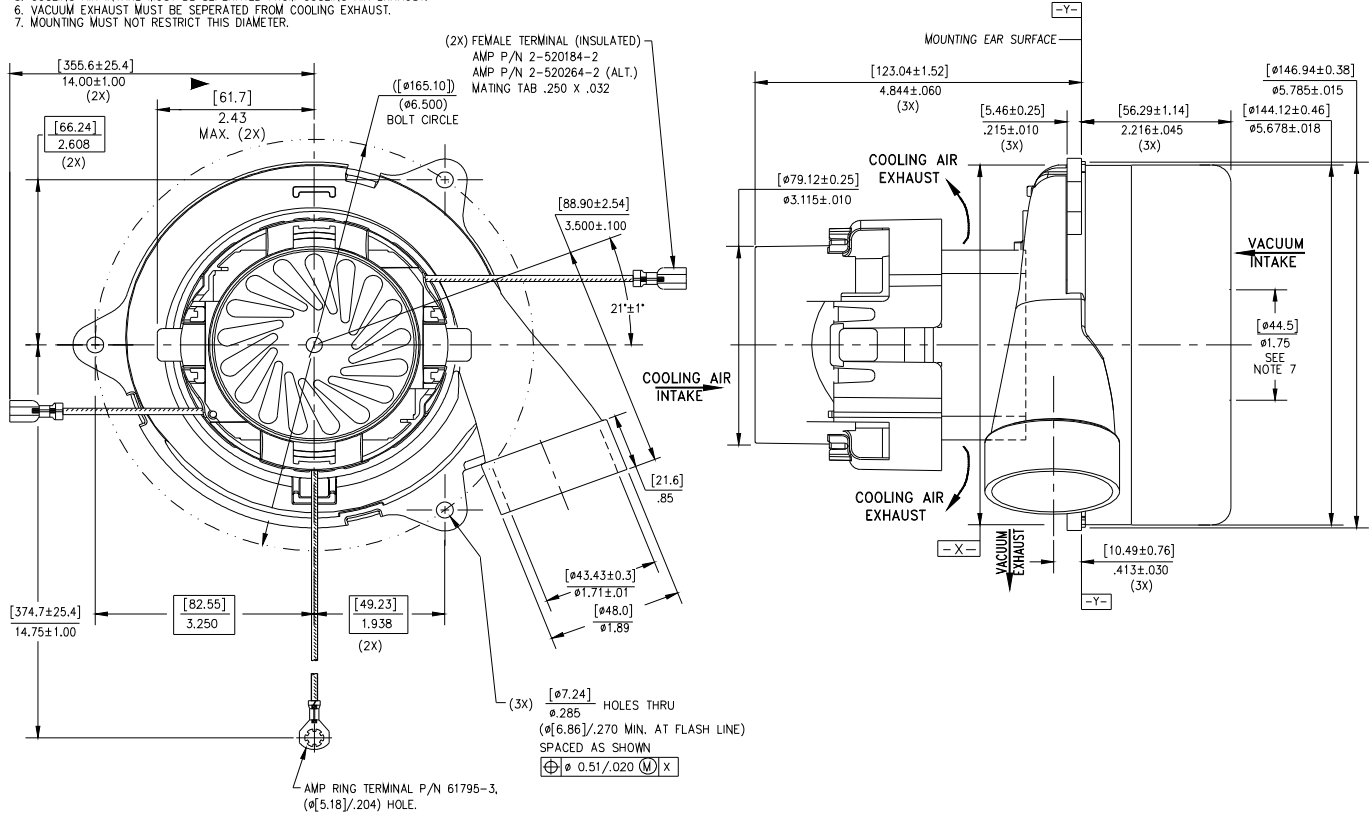

IMPORTANT NOTE: Pictorial and dimensional data are subject to change without notice. Contact factory for current revision levels.

WARNING - When using AMETEK Lamb Electric bypass motors in machines that come in contact with foam, liquid (including water), or other foreign substances, the machine must be designed and constructed to prevent those substances from reaching the fan system, motor housing, and electrical components. Lamb Electric vacuum motors other than hazardous duty models should not be applied in machines that come in contact with dry chemicals or other volatile materials. Failure to observe these precautions could cause flashing (depending on volatility) or electrical shock which could result in property damage and severe bodily injury, including death in extreme cases. All applications incorporating Lamb Electric motors should be submitted to appropriate organizations or agencies for testing specifically related to the safety of your equipment.

AMETEK/Lamb Electric Division
627 Lake Street
Kent, Ohio 44240
U.S.A.
Tel: (330) 673-3786 Fax: (330) 677-3812
www.lambelectric.com